



# CATÁLOGO DE PRODUCTOS

## REPUESTOS



**Gr 280**

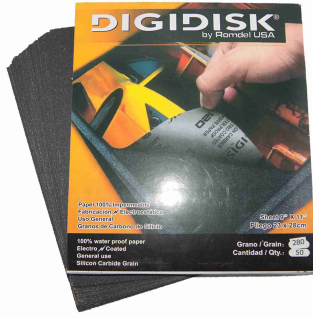

**DIGIDISK**

**ABR-0280 REF A 17**  
PQT |LIJA PREMIER GRANO 280. CARBO/  
DIGID  
**REF B=25.87 REF C=27.23**

**Gr 320**

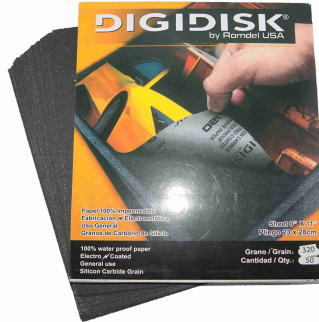

**DIGIDISK**

**ABR-0320 REF A 17**  
PQT |LIJA PREMIER GRANO 320. CARBO/  
DIGID  
**REF B=25.87 REF C=27.23**

**Gr 240**



**ZASC**

**ABR-0780 REF A 3.51**  
PQT |LIJA AGUA IMPERMEAB.ZASC #240  
25PZA  
**REF B=5.34 REF C=5.62**

**Gr 280**



**ZASC**

**ABR-0785 REF A 3.51**  
PQT |LIJA AGUA IMPERBEAB.ZASC #280  
25PZA  
**REF B=5.34 REF C=5.62**

**Gr 320**



**ZASC**

**ABR-0790 REF A 3.51**  
PQT |LIJA AGUA IMPERMEAB.ZASC #320  
25PZA  
**REF B=5.34 REF C=5.62**

**Gr 360**



**ZASC**

**ABR-0795 REF A 3.51**  
PQT |LIJA AGUA IMPERMEAB.ZASC #360  
25PZA  
**REF B=5.34 REF C=5.62**

**Gr 400**



**ZASC**

**ABR-0800 REF A 3.51**  
PQT |LIJA AGUA IMPERMEAB.ZASC #400  
25PZA  
**REF B=5.34 REF C=5.62**

**Gr 600**



**ZASC**

**ABR-0840 REF A 3.51**  
PQT |LIJA AGUA IMPERMEAB.ZASC #600  
25PZA  
**REF B=5.34 REF C=5.62**

**Gr 100**



**DIESEL TOOLS**

**ABR-0853 REF A 5.9**  
PQT |LIJA AGUA CASTOR/DISEL TOOL  
GR#100  
**REF B=8.97 REF C=9.44**



**120gr**



**ABR-0856 REF A 6.11**  
 PQT | LIJA AGUA DIESEL TOOLS GRANO # 120  
**REF B=9.3 REF C=9.79**



**Gr 180**



**ABR-0861 REF A 5.9**  
 PQT | LIJA AGUA SPEED/DIESEL TOOLS GR#180  
**REF B=8.97 REF C=9.44**



**#220**



**ABR-0863 REF A 7.03**  
 PQT | LIJA AGUA SPEED/DIESEL TOOLS GR#220  
**REF B=10.7 REF C=11.26**



**Gr 180**



**ABR-0915 REF A 60.48**  
 PQT | LIJA AL AGUA 3M SERIE 431Q GR 180  
**REF B=92.05 REF C=96.89**



**7x 1/8x7/8"**



**ABR-2033 REF A 0.86**  
 PZA | DISCO P/CORT.PLAN.7 X 1/8X7/8 WOLF  
**REF B=1.31 REF C=1.38**



**7"x1/4" x7/8"**



**ABR-2035 REF A 1.19**  
 PZA | DISCO P/ESMERI.DCR 7X1/4X 7/8 HA FM  
**REF B=1.8 REF C=1.9**



**4.1/2"**



**ABR-2155 REF A 4.33**  
 PZA | DISC.POLICARB.PREMIU.4.5"REMOV.PIN T  
**REF B=6.58 REF C=6.93**



**6"x1M Gr 36**



**ABR-5900 REF A 4.51**  
 RLL | LIJA TELA ROLLITO 6"GR 36 X 1 MTS  
**REF B=6.87 REF C=7.23**



**5/8" 11-20mm**



**ABZ-1010 REF A 0.24**  
 PZA | ABRAZ.INOXID.C/TORN INOX.5/8 11-20M  
**REF B=0.36 REF C=0.38**



**1/2"-3/4"  
13-19mm**



**ZASC**

**ABZ-1015 REF A 1.39**  
PQT |ABRAZ.INOX.13-19M 1/2-3/4 PQ10  
HC34  
**REF B=2.11 REF C=2.22**



**ABZ-1025 REF A 0.34**  
PZA |ABRAZ.INOXID.C/TORN.INOX.1  
20-32M.  
**REF B=0.51 REF C=0.54**

**1"  
20-30mm**



**ZASC**

**ABZ-1035 REF A 2.91**  
PQT |ABRAZ.INOX.19-44M 3/4-1.3/4 P10  
134  
**REF B=4.42 REF C=4.66**



**3/4x1.3/4"  
19-44mm**



**3/8"  
6-10mm**



**Wolfgang**

**ABZ-2310 REF A 0.05**  
PZA |ABRAZADERA GALVZ S/F  
3/8"6-10mmIMP.  
**REF B=0.08 REF C=0.08**



**3/8" - 6-10mm  
PQT 50 PZAS**



**Q7**

**ABZ-2312 REF A 2.96**  
PQT |ABRAZAD.GALVZ S/F 3/8"6-10m  
PQT-50P  
**REF B=4.5 REF C=4.74**



**1/2"  
11-20mm**



**Wolfgang**

**ABZ-2320 REF A 0.07**  
PZA |ABRAZADERA GALVZ S/F 1/2"  
11-20mIMP  
**REF B=0.11 REF C=0.11**



**5/8" - 10-16mm  
PQT 50 PZAS**



**Q7**

**ABZ-2323 REF A 3.16**  
PQT |ABRAZAD.GALVZ S/F 5/8"10-16m  
PQT50PZ  
**REF B=4.8 REF C=5.06**



**5/8"  
12-25m**



**DIESEL TOOLS**

**ABZ-2330 REF A 0.09**  
PZA |ABRAZADERA GALVZ S/F 5/8"12-25m  
IMP  
**REF B=0.14 REF C=0.14**



**3/4"  
13-19mm**



**Wolfgang**

**ABZ-2360 REF A 0.11**  
PZA |ABRAZADERA GALVZ S/F 3/4"13-19m  
IMP  
**REF B=0.17 REF C=0.18**



**7/8"**  
**20-31mm**



**ABZ-2361 REF A 0.13**  
PZA | ABRAZADERA GALVZ S/F 7/8"20-31m  
IMP  
REF B=0.2 REF C=0.21

**1.1/2"**  
**21-38mm**



**ABZ-2363 REF A 0.17**  
PZA | ABRAZADERA GALVZ S/F 1.1/2  
21-38MM  
REF B=0.26 REF C=0.27

**20-40mm**



**ABZ-3204 REF A 1.1**  
PZA | ABRAZADERA GALVZ.ANCHA H.D  
20-40MM  
REF B=1.68 REF C=1.77

**60-80mm**



**ABZ-3212 REF A 1.4**  
PZA | ABRAZADERA GALVZ.ANCHA H.D  
60-80MM  
REF B=2.13 REF C=2.24

**120-140**  
**mm**



**ABZ-3224 REF A 1.9**  
PZA | ABRAZADER.GALVZ.ANCHA H.D  
120-140M  
REF B=2.89 REF C=3.04

**44-47mm**



**ABZ-3391 REF A 0.98**  
PZA | ABRAZADER.EXTR.FUERT.C/  
TORN.44-47M  
REF B=1.5 REF C=1.58

**188-200**  
**mm**



**ABZ-3451 REF A 7.99**  
PZA | ABRAZADER.EXTR.FUERT.C/  
TOR.188-200  
REF B=12.16 REF C=12.8

**6"**



**ABZ-3709 REF A 4.4**  
PZA | ABRAZADERA COLGANT.P/TUB.H  
NEGR.6"  
REF B=6.69 REF C=7.04

**1/2HP**



**AHD-0450 REF A 0.78**  
PZA | CAJA TERMINAL P/BOMBA AGUA 1/2  
HP  
REF B=1.19 REF C=1.26

**1/2HP  
20uF**



**AHD-0510 REF A 1.05**  
PZA |CAPACITOR BOMB AGUA 1/2HP 20uF  
REF B=1.6 REF C=1.69

**3/4HP**



**CR-Turb**

**AHD-0522 REF A 3.06**  
PZA |CAPACITOR P/BOMBA AGUA 3/4 HP  
27uF  
REF B=4.65 REF C=4.9

**60MF  
300V**



**PEDROLLO**

**AHD-0620 REF A 21.11**  
PZA |CONDENSADOR 60MF 300V BIF  
PEDROLLO  
REF B=32.12 REF C=33.81

**80MF  
250V**



**80uF ± 5%**

**80uF ± 5%**

**PEDROLLO**

**AHD-0627 REF A 26.71**  
PZA |CONDENSADOR 80MF 250V MON  
PEDROLLO  
REF B=40.65 REF C=42.78

**9cm**



**HTK HIDROTEK**

**AHD-0675 REF A 5.51**  
PZA |CONEXION 5 VIAS BRON.9CM P/  
HIDRON  
REF B=8.39 REF C=8.83

**3/4HP**



**WEQUP**

**AHD-0705 REF A 2.22**  
PZA |CUBIERTA D/VENTILADOR P/  
BOMB.3/4 HP  
REF B=3.38 REF C=3.56

**15A-125V  
3M**



**FM  
FERMETAL**

**AHD-3000 REF A 6.51**  
PZA |FLOTANTE ELECTRI.15A 125V  
CAB/3MTS.  
REF B=9.91 REF C=10.43

**15A-125V**



**FM  
FERMETAL**

**AHD-3003 REF A 15.1**  
PZA |FLOTANT ELECT.15A 125V CAB-  
CONTRAP  
REF B=22.98 REF C=24.19

**3/4HP**



**AHD-4505 REF A 2.99**  
PZA |IMPELLER BRONCE P/BOMBA AGUA  
3/4HP  
REF B=4.55 REF C=4.79

**1/2"**

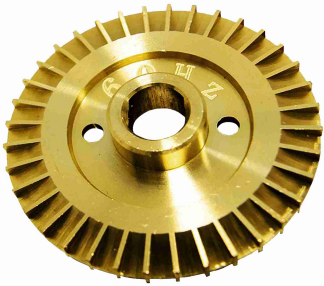

**AHD-4517 REF A 12.93**  
PZA | IMPEL.B/A PKM60 1/2"S/CHAVETERO  
PED  
**REF B=19.68 REF C=20.72**

**1 HP**



**AHD-4519 REF A 37.05**  
PZA | IMPELLER CONICO INOX CP620 1HP  
PEDR  
**REF B=56.39 REF C=59.35**

**1.1/2HP**



**AHD-4521 REF A 46.3**  
PZA | IMPELLER CONICO INOX CP650 1.1/2  
PE  
**REF B=70.47 REF C=74.17**

**3 HP**



**AHD-4525 REF A 55.83**  
PZA | IMPELLER.CONICO INOX CP670 3HP  
PEDR  
**REF B=84.98 REF C=89.44**

**5.5HP**

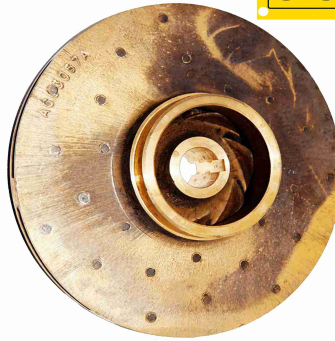

**AHD-4527 REF A 136.14**  
PZA | IMPELLER.BRONCE.CP680C 5.5H  
PEDROL  
**REF B=207.21 REF C=218.1**

**15 HP**



**AHD-4533 REF A 188.62**  
PZA | IMPELLE.P/BOMBA.CP750C 15HP  
PEDROLL  
**REF B=287.08 REF C=302.17**

**25 HP**



**AHD-4535 REF A 173.1**  
PZA | IMPELLE.P/BOMBA.CP750A 25HP  
PEDROLL  
**REF B=263.45 REF C=277.3**

**1/2"**



**AHD-4750 REF A 32.26**  
PZA | KIT.REPARC.(IMPEL+SELLO)1/2  
PEDROLL  
**REF B=49.1 REF C=51.68**

**1/2"**  
**2 LITROS**



**AHD-4800 REF A 31.25**  
PZA | KIT HIDROCOM.1/2  
2LT(TE\*TANQ\*MAN\*PR)  
**REF B=47.57 REF C=50.07**

**1/2"**  
5 LITROS



**AHD-4808 REF A 38.03**  
PZA |KIT HIDRO.1/2  
5LT.TE\*TANQ\*MAN\*PRES.  
REF B=57.88 REF C=60.92

**1/2"**  
24 LITROS



**AHD-4815 REF A 56.92**  
PZA |KIT HIDRO.1/2  
24LT(TE\*TANQ\*MAN\*PRE)  
REF B=86.63 REF C=91.18

**1"-1/4"**



**AHD-5200 REF A 7.01**  
PZA |NIPLE SUCCION 1"SALID 1/4 P/  
HIDROMA  
REF B=10.67 REF C=11.23

**20-40Psi**



**AHD-6500 REF A 4.26**  
PZA |PRESOSTATO MINI 20-40 PSI P/BOMBA  
REF B=6.49 REF C=6.83

**20-40PSI**

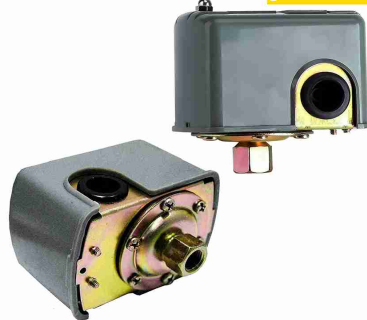

**AHD-6507 REF A 3.41**  
PZA |PRESOSTATO P/BOMBA 20-40PSI  
GRIMX  
REF B=5.19 REF C=5.46

**1HP-24L**



**AHD-6515 REF A 10.19**  
PZA |PRESOST.HIDROCOMP.1 HP 24L  
AHD-4815  
REF B=15.5 REF C=16.32

**1.5 BAR**  
110v



**AQUA PLUS**

**AHD-6550 REF A 24.65**  
PZA |PRESS CONTROL 1.5 BAR 110V  
AQU-645  
REF B=37.52 REF C=39.49

**1/2HP**  
6201RS



**AHD-7200 REF A 0.79**  
PZA |ROLINERA P/BOMBA AGUA 1/2 HP  
QB-60.  
REF B=1.2 REF C=1.26

**3/4HP**  
6202RS



**AHD-7205 REF A 0.84**  
PZA |ROLINERA P/BOMBA AGUA 3/4 HP  
QB-70.  
REF B=1.27 REF C=1.34





**1/2"**

**AHD-8690 REF A 0.57**  
 PZA | SELLO MECAN. BOM-AGUA 1/2 CORTO 12MM  
**REF B=0.86 REF C=0.91**



**1/2" x12mm**

**AHD-8700 REF A 0.47**  
 PZA | SELLO MECANIC P/BOMBA AGUA 1/2 12MM  
**REF B=0.71 REF C=0.75**



**3/4" x14mm**

**AHD-8705 REF A 0.7**  
 PZA | SELLO MECANIC P/BOMBA AGUA 3/4 14MM  
**REF B=1.07 REF C=1.12**



**1"-16mm**

**AHD-8710 REF A 0.95**  
 PZA | SELLO MECANICO./BOMBA AGUA 1" 16MM  
**REF B=1.45 REF C=1.52**



**1"-5L**

**AHD-8855 REF A 25.59**  
 PZA | TANQUE SOLO 5 LTS P/HIDRO. ROSC 1"  
**REF B=38.95 REF C=41**



**1"-50L**

**AHD-8885 REF A 48.18**  
 PZA | TANQUE SOLO 50 LTS P/HIDRO. ROSC 1"  
**REF B=73.33 REF C=77.18**



**1/2HP**

**AHD-9000 REF A 0.3**  
 PZA | VENTILADOR PARA BOMBA AGUA 1/2 HP  
**REF B=0.46 REF C=0.48**



**1HP**

**AHD-9004 REF A 0.7**  
 PZA | VENTILADOR PARA BOMBA AGUA 1"HP  
**REF B=1.07 REF C=1.12**



**3/4HP**

**AHD-9012 REF A 4.77**  
 PZA | VENTILAD.P/BOMB AGUA MEC71 3/4 PEDR  
**REF B=7.27 REF C=7.65**



**80mm**



**GMP**

APH-2015 REF A 0.12  
PZA | EMBUDO MINI PLASTICO PVC 80MM

REF B=0.18 REF C=0.19

**#1**



**GMP**

APH-2017 REF A 0.32  
PZA | EMBUDO PLASTICO # 1

REF B=0.49 REF C=0.52

**#2**



**GMP**

APH-2018 REF A 0.57  
PZA | EMBUDO PLASTICO # 2

REF B=0.87 REF C=0.92

**#3**



**GMP**

APH-2019 REF A 0.76  
PZA | EMBUDO PLASTICO # 3

REF B=1.16 REF C=1.22

**1/4"x60mm  
120kg**



**DIESEL TOOLS**

APH-3915 REF A 0.48  
PZA | LLAVERO ALPINISTA ALUM.1/4X60M  
120K

REF B=0.74 REF C=0.78

**6 PCS**



**PONY**

APH-3923 REF A 5.41  
DIS | LLAVER.METAL CROM.DISP-6Pz PON  
857A

REF B=8.24 REF C=8.67

**12PCS**



APH-3930 REF A 7.95  
DIS | LLAVER MULT.MET.MED.T/GANCHO  
466 12P

REF B=12.1 REF C=12.74

**12PCS**



APH-3932 REF A 10.81  
DIS | LLAV.M.MET.GRD.T/GANCH 2ARO  
422 12P

REF B=16.46 REF C=17.32

**MEDIANA  
12 PCS**



APH-3933 REF A 2.25  
DIS | LLAVER ALPINIST.ALUM.MED.COLOR  
12P

REF B=3.43 REF C=3.61



**GRANDE  
12 PCS**



**APH-3934 REF A 3.92**  
DIS | LLAVER ALPINIST.ALUM.GRAN.COLOR  
12P  
**REF B=5.97 REF C=6.29**



**GRANDE  
12 PCS**



**APH-3935 REF A 3.74**  
DIS | LLAVERO ALPINISTA  
ALUM.GRAN.DISP.12  
**REF B=5.69 REF C=5.99**



**GRANDE  
12 PCS**



**APH-3936 REF A 6.97**  
DIS | LLAV.ALPINIS.PLANO  
ALUM.GRD.COLO.12P  
**REF B=10.62 REF C=11.17**

**5.1/2cm**



**APH-3937 REF A 0.66**  
PZA | LLAVERO  
MULTIUS.MOSQUE.CROM.5.1/2CM  
**REF B=1.01 REF C=1.06**



**1/2"x78mm  
150Kgs**



**APH-3938 REF A 0.99**  
PZA | LLAVERO  
M.MOSQUET.CROM.1/2-78M-150K  
**REF B=1.5 REF C=1.58**

**1/2"**



**APH-3941 REF A 1.67**  
PZA | LLAVERO M.MOSQUET.LATON.1/2  
SF-1/2  
**REF B=2.54 REF C=2.68**

**3/4"**



**APH-3942 REF A 2.27**  
PZA | LLAVERO M.MOSQUET.LATON.3/4  
SF-3/4  
**REF B=3.46 REF C=3.64**

**1"**



**APH-3943 REF A 2.56**  
PZA | LLAVERO M.MOSQUET.LATON.1" SF-1"  
**REF B=3.89 REF C=4.09**

**10-12  
PZA**



**APH-3947 REF A 0.6**  
PQT | LLAVER.PLAST.COLOR.SURT.PQT  
12/10Pz  
**REF B=0.92 REF C=0.96**



**20 PZAS**



**APH-3949 REF A 0.82**  
PQT |LLAVERO PLAST.COLOR.SURT.PQT  
20Pz DI  
**REF B=1.25 REF C=1.31**



**2x18-100M**



**CBL-1220 REF A 16.92**  
RLL | CABLE SPT 2X18 PARALELO BLANCO  
TRIC  
**REF B=25.75 REF C=27.1**



**100M  
2x16AWG**



**CBL-1250 REF A 52.1**  
RLL | CABLE SPT 2 X 16 100% COBRE DIESEL  
**REF B=79.3 REF C=83.47**



**2x20 AWG  
100 M**



**CBL-2065 REF A 11.82**  
RLL | CABLE CORNETA 2X20 ROJO/NEGRO  
100MT  
**REF B=18 REF C=18.94**



**1/4"**

**CGA-0952 REF A 0.22**  
PZA |60-FS ANILLO DE COMPRESION 1/4"  
**REF B=0.34 REF C=0.36**



**5/16"**

**CGA-0954 REF A 0.25**  
PZA |60-FS ANILLO DE COMPRESION 5/16"  
**REF B=0.39 REF C=0.41**



**3/8"**

**CGA-0956 REF A 0.28**  
PZA |60-FS ANILLO DE COMPRESION 3/8"  
**REF B=0.43 REF C=0.45**



**1/2"**

**CGA-0958 REF A 0.43**  
PZA |60-FS ANILLO DE COMPRESION 1/2"  
**REF B=0.66 REF C=0.69**



**5/16" x 1/8"  
NPTHB**

**CGA-0997 REF A 1.06**  
PZA |204 CONEC.MANG.ESPG.1/4X1/8 NPT  
HB  
**REF B=1.61 REF C=1.69**

**ESPG.5/16"  
x1/4" NPTHB**



**CGA-1002 REF A 1.52**  
PZA |204  
CONEC.MANG.ESPG.5/16X1/4NPTHB  
**REF B=2.31 REF C=2.43**

**5/16x3/8"**



**CGA-1004 REF A 2.07**  
PZA |204  
CONEC.MANG.ESPG.5/16X3/8NPTHB  
**REF B=3.15 REF C=3.32**



**CGA-1007 REF A 1.1**  
PZA |204-S CONEXION PARA COCINA  
CAMPING  
**REF B=1.68 REF C=1.77**

**1/4"x1/4"**



**CGA-1009 REF A 1.52**  
PZA |204-P  
CONEC.MANG.ESPG.1/4NPTX1/4HB  
**REF B=2.31 REF C=2.43**

**3/8"x3/8"**



**CGA-1010 REF A 1.91**  
PZA |204-P  
CONEC.MANG.ESPG.3/8NPTX3/8HB  
**REF B=2.9 REF C=3.06**

**ESPG.3/8"  
x1/2"NPTHB**



**AQUA PLUS**

**CGA-1013 REF A 1.34**  
PZA |204S  
CONEC.MANG.ESPG.3/8NPTX1/2HB  
**REF B=2.04 REF C=2.15**

**ESPG.1/2"  
x1/2"NPTHB**



**CGA-1014 REF A 1.19**  
PZA |204-P  
CONE.MANG.ESP.1/2NPTX1/2HEMB  
**REF B=1.8 REF C=1.9**

**3/16"**



**CGA-1015 REF A 0.49**  
PZA |41-S COPA SAE 3/16 STD  
**REF B=0.75 REF C=0.79**

**1/4"**



**CGA-1016 REF A 0.55**  
PZA |41-S COPA SAE 1/4 STD.  
**REF B=0.84 REF C=0.88**

**5/16"**



**CGA-1018 REF A 0.77**  
PZA |41-S COPA SAE 5/16 STD.

**REF B=1.18 REF C=1.24**

**3/8"**



**CGA-1027 REF A 1.09**  
PZA |41-S COPA SAE 3/8 STD. CORTA

**REF B=1.66 REF C=1.74**

**1/2"**



**CGA-1032 REF A 1.62**  
PZA |41-S COPA SAE 1/2 STD.

**REF B=2.47 REF C=2.6**

**5/8"**



**CGA-1033 REF A 2.68**  
PZA |41-S COPA SAE 5/8 STD.

**REF B=4.08 REF C=4.3**

**3/4"**



**CGA-1034 REF A 4.47**  
PZA |41-S COPA SAE 3/4 STD.

**REF B=6.8 REF C=7.16**

**1/4"**



**CGA-1036 REF A 0.73**  
PZA |641-S COPA ALTA PRESION SAE 1/4

**REF B=1.11 REF C=1.17**

**3/8"**

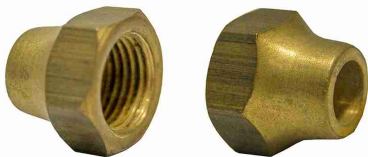

**CGA-1038 REF A 1.36**  
PZA |641-S COPA ALTA PRESION SAE 3/8

**REF B=2.06 REF C=2.17**

**1/2"**

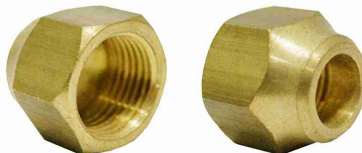

**CGA-1039 REF A 1.79**  
PZA |641-S COPA ALTA PRESION SAE 1/2

**REF B=2.72 REF C=2.86**

**3/8" SAE  
x3/8" NPT**



**AQUA PLUS**

**CGA-1045 REF A 0.98**  
PZA |48-S CONECTOR 3/8 SAE X 3/8 NPT.

**REF B=1.49 REF C=1.57**

**3/8" SAE  
x1/2" NPT**



**AQUA PLUS**

**CGA-1047 REF A 1.42**  
PZA |48-S CONECTOR 3/8 SAE X 1/2 NPT.

**REF B=2.16 REF C=2.28**

**1/2" SAE  
x1/2" NPT**



**CGA-1050 REF A 1.51**  
PZA |48-S CONECTOR 1/2 SAE X1/2 NPT  
MACH

**REF B=2.29 REF C=2.41**



**CGA-1059 REF A 1.09**  
PZA |48WP CONEC.FUNCION T CHECK  
1 BOMBONA

**REF B=1.66 REF C=1.74**

**1/8" NPTM**



**CGA-1065 REF A 1.22**  
PZA |PRI1B-D PICO DIGASMATIC 1/8" NPTM

**REF B=1.86 REF C=1.96**

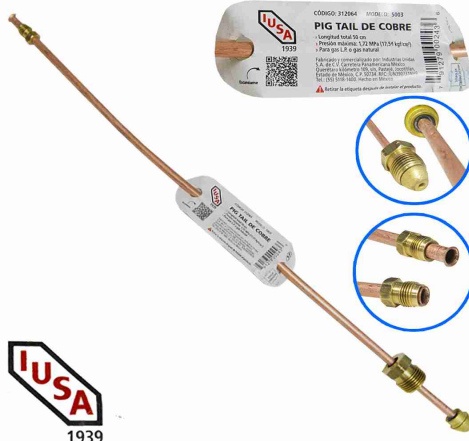

**CGA-1074 REF A 6.35**  
PZA |1495 CONEXION POOL ECON.COBR

**REF B=9.66 REF C=10.16**

**1/4" SAE  
x1/4" NPT**



**CGA-1076 REF A 1.31**  
PZA |46-S REDUCTOR 1/4 SAE X 1/4 NPT  
HEMB

**REF B=2 REF C=2.1**

**3/8" SAE  
x3/8" NPT**



**CGA-1085 REF A 1.62**  
PZA |46-S REDUCTOR 3/8 SAE X 3/8 NPT  
HEM

**REF B=2.47 REF C=2.6**

**3/8" SAE  
x1/2" NPT**

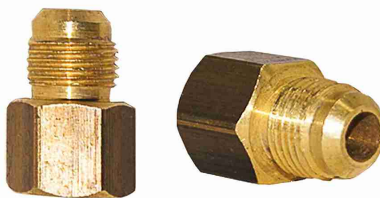

**CGA-1087 REF A 2.31**  
PZA |46-S REDUCTOR 3/8 SAE X 1/2 NPT  
HEM

**REF B=3.52 REF C=3.7**

**3/8" x3/8"**



**CGA-1094 REF A 0.88**  
PZA |206-S UNION ESPIGA P/  
MANG.3/8X3/8"

**REF B=1.34 REF C=1.41**

**1/4x1/4"**



**CGA-1096 REF A 0.75**  
PZA |206-S UNION ESPIGA P/  
MANG.1/4X1/4"  
**REF B=1.13 REF C=1.19**

**1/2x1/2"**



**CGA-1098 REF A 1.33**  
PZA |206-S UNION ESPIGA P/  
MANG.1/2X1/2"  
**REF B=2.02 REF C=2.12**

**5/16"  
x3/16"**



**CGA-1113 REF A 0.72**  
PZA |41-WR TUERC.FLAR.INV  
5/16nptx3/16t  
**REF B=1.09 REF C=1.15**

**5/16"  
x1/4"**



**CGA-1115 REF A 0.69**  
PZA |41-WR TUERC.FLARE INV  
5/16nptx1/4t  
**REF B=1.04 REF C=1.1**

**3/8"  
x1/4"**



**CGA-1117 REF A 1.1**  
PZA |41-WR TUERC.FLARE INV 3/8nptx1/4t  
**REF B=1.68 REF C=1.77**

**3/16"**



**CGA-1118 REF A 0.4**  
PZA |41-W TUERCA FLARE INV 3/16.  
**REF B=0.61 REF C=0.64**

**1/4"**



**CGA-1119 REF A 0.48**  
PZA |41-W TUERCA FLARE INV 1/4.  
**REF B=0.73 REF C=0.76**

**5/16"**



**CGA-1120 REF A 0.6**  
PZA |41-W TUERCA FLARE INV 5/16.  
**REF B=0.91 REF C=0.95**

**3/8"**



**CGA-1121 REF A 1.09**  
PZA |41-W TUERCA FLARE INV 3/8"  
**REF B=1.66 REF C=1.74**



**3/16"**



**CGA-1123 REF A 0.46**  
PZA |41-WL TUERCA FLARE INV LARGA 3/16

**REF B=0.7 REF C=0.74**

**1/4"**



**CGA-1124 REF A 0.54**  
PZA |41-WL TUERCA FLARE INV LARGA 1/4"

**REF B=0.82 REF C=0.86**

**3/8"**



**CGA-1125 REF A 1.4**  
PZA |41-WL TUERCA FLARE INV LARGA 3/8"

**REF B=2.13 REF C=2.24**

**5/16"**



**CGA-1126 REF A 0.72**  
PZA |41-WL TUERCA FLARE INV LARGA 5/16

**REF B=1.09 REF C=1.15**

**D10-10**



**CGA-1127 REF A 4.57**  
PZA |D10-10 TUERCA REGULADOR D/  
OXIGENO

**REF B=6.96 REF C=7.33**

**3/8" SAE  
X 3/8" SAE**



**CGA-1129 REF A 1.48**  
PZA |42-S UNION 3/8 SAE X 3/8 SAE.

**REF B=2.25 REF C=2.36**

**1/2" SAE  
X 1/2" SAE**



**CGA-1131 REF A 2.53**  
PZA |42-S UNION 1/2 SAE X 1/2 SAE.

**REF B=3.86 REF C=4.06**

**1/2"**



**CGA-1140 REF A 10.44**  
PZA |44-S TEE SAE x SAE x SAE 1/2

**REF B=15.89 REF C=16.72**

**3/16"  
x 3/16"**



**CGA-1200 REF A 1.58**  
PZA |62-S UNION COMPRE.ARMADA  
3/16X3/16

**REF B=2.4 REF C=2.53**

**1/4"x1/4"**



**CGA-1202 REF A 1.88**  
PZA |62-S UNION COMPRES.ARMADA  
1/4X1/4  
**REF B=2.86 REF C=3.01**

**5/16"  
x5/16"**



**CGA-1215 REF A 2.19**  
PZA |62-S UNION  
COMPRES.ARMAD.5/16X5/16  
**REF B=3.33 REF C=3.51**

**3/8x3/8"**



**CGA-1217 REF A 2.56**  
PZA |62-S UNION COMPRES.ARMADA  
3/8X3/8  
**REF B=3.9 REF C=4.11**

**1/2"x1/2"**



**CGA-1219 REF A 4.05**  
PZA |62-S UNION COMPRES.ARMADA  
1/2X1/2  
**REF B=6.17 REF C=6.49**

**5/8"x5/8"**



**CGA-1221 REF A 6.15**  
PZA |62-S UNION COMPRES.ARMADA  
5/8X5/8  
**REF B=9.37 REF C=9.86**

**3/4"x3/4"**



**CGA-1223 REF A 9.74**  
PZA |62-S UNION COMPRES.ARMADA  
3/4X3/4  
**REF B=14.83 REF C=15.61**

**1/8x1/8"**



**CGA-1225 REF A 1.4**  
PZA |66-S  
CONECT.COMP.ARM.1/8NPTX1/8HEMB  
**REF B=2.13 REF C=2.24**

**1/4"  
x1/8"**



**CGA-1227 REF A 1.46**  
PZA |66-S  
CONECT.COMP.ARM.1/4NPTX1/8HEMB  
**REF B=2.22 REF C=2.34**

**3/8"  
x1/2"**

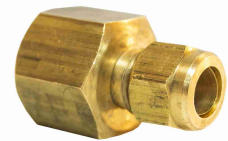

**CGA-1240 REF A 3.26**  
PZA |66-S  
CONECT.COMP.ARM.3/8NPTX1/2HEMB  
**REF B=4.97 REF C=5.23**

**1/4x3/8"**



**CGA-1266 REF A 2.09**  
PZA |68-F CONECT.MACH COMPR/  
ARM.1/4x3/8  
**REF B=3.17 REF C=3.34**

**1/4x1/2"**



**CGA-1267 REF A 2.99**  
PZA |68-F CONEC.MACH COMPR/  
ARM.1/4x1/2 NPT  
**REF B=4.56 REF C=4.8**

**3/8x1/2"**



**CGA-1271 REF A 1.74**  
PZA |68-F CONEC.MACH COMPR/  
ARM.3/8x1/8 NPT  
**REF B=2.65 REF C=2.79**

**3/8x1/2"**



**CGA-1274 REF A 2.98**  
PZA |68-F CONEC.MACH COMPR/  
ARM.3/8x1/2 NPT  
**REF B=4.54 REF C=4.77**

**1/2x1/2"**



**CGA-1277 REF A 3.52**  
PZA |68-F CONEC.MACH COMPR/  
ARM.1/2x1/2 NPT  
**REF B=5.35 REF C=5.63**

**1/8"**



**CGA-1352 REF A 0.63**  
PZA |108-BP TAPA NPT HEMBRA 1/8"  
**REF B=0.95 REF C=1**

**1/4"**



**CGA-1353 REF A 0.97**  
PZA |108-BP TAPA NPT HEMBRA 1/4"  
**REF B=1.47 REF C=1.55**

**3/8"**



**CGA-1354 REF A 1.5**  
PZA |108-BP TAPA NPT HEMBRA 3/8"  
**REF B=2.29 REF C=2.41**

**1/2"**



**CGA-1355 REF A 2.31**  
PZA |108-BP TAPA NPT HEMBRA 1/2"  
**REF B=3.52 REF C=3.7**

**3/8"x1/8"**



**CGA-1357 REF A 1.19**  
PZA |110-B BUSHING REDUCTOR 3/8 x 1/8

**REF B=1.81 REF C=1.91**

**3/8"x1/4"**



**CGA-1360 REF A 1.06**  
PZA |110-B BUSHING REDUCTOR 3/8 x 1/4

**REF B=1.61 REF C=1.69**

**1/2x3/8"**



**CGA-1364 REF A 1.48**  
PZA |110-B BUSHING REDUCTOR 1/2 x 3/8

**REF B=2.25 REF C=2.36**

**5/16"**



**CGA-1521 REF A 0.34**  
PZA |459-S INSERTO P/MANGUERA 5/16

**REF B=0.52 REF C=0.55**

**1/4" MACHO**



**CGA-1532 REF A 1.1**  
PZA |122-B NIPLE HEXAGONAL NPT MACH.1/4

**REF B=1.68 REF C=1.77**

**1/2" MACHO**



**CGA-1534 REF A 2.53**  
PZA |122-B NIPLE HEXAGONAL NPT MACHO 1/2

**REF B=3.86 REF C=4.06**

**1/2"x1/4"**



**CGA-1539 REF A 2.43**  
PZA |123-B NIPLE HEX.REDUCI.NPT 1/2x1/4

**REF B=3.7 REF C=3.89**

**1/2"x3/8"**



**CGA-1541 REF A 2.4**  
PZA |123-B NIPLE HEX.REDUCI.NPT 1/2x3/8

**REF B=3.65 REF C=3.84**

**3/8"**



**CGA-1572 REF A 7.78**  
PZA |101-B TEE NPT 3/8

**REF B=11.84 REF C=12.46**

**1/2"**



**CGA-1573 REF A 13.22**  
PZA |101-B TEE NPT 1/2

**REF B=20.11 REF C=21.17**

**1/8" NPT**



**CGA-1579 REF A 0.8**  
PZA |103-B ANILLO NPT 1/8

**REF B=1.22 REF C=1.29**

**1/4" NPT**

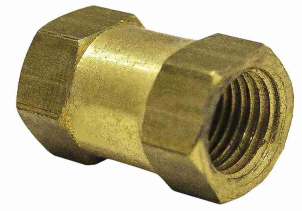

**CGA-1580 REF A 1.1**  
PZA |103-B ANILLO NPT 1/4

**REF B=1.68 REF C=1.77**

**3/8"**



**CGA-1583 REF A 1.64**  
PZA |103-B ANILLO NPT 3/8

**REF B=2.49 REF C=2.63**

**1/2"**



**CGA-1584 REF A 2.61**  
PZA |103-B ANILLO NPT 1/2"

**REF B=3.97 REF C=4.18**

**1/2"x3/8"  
NPT**



**CGA-1594 REF A 2.77**  
PZA |119-B REDUCTOR HEMBRA NPT  
1/2x3/8

**REF B=4.22 REF C=4.44**

**1/4x1/8"  
MACHO**



**CGA-1604 REF A 1.1**  
PZA |120-B ADAPTADOR HNPTxMNPT  
1/4x1/8

**REF B=1.68 REF C=1.77**

**3/8x1/4"  
MACHO**



**CGA-1606 REF A 1.65**  
PZA |120-B ADAPTADOR HNPTxMNPT  
3/8x1/4

**REF B=2.52 REF C=2.65**

**1/2"x3/8"  
MNPTxHNPT**



**CGA-1610 REF A 2.86**  
PZA |120-B ADAPTADOR HNPTxMNPT  
1/2x3/8

**REF B=4.35 REF C=4.58**

**1/8" HNPT**



**CGA-1612 REF A 0.51**  
PZA | 109-B TAPON NPT CAB.HEXA.1/8  
109BP  
**REF B=0.77 REF C=0.81**

**1/4" HNPT**



**CGA-1614 REF A 0.8**  
PZA | 109-B TAPON NPT CAB.HEXA.1/4  
109BP  
**REF B=1.22 REF C=1.29**

**3/8" HNPT**



**CGA-1615 REF A 1.1**  
PZA | 109-B TAPON NPT CAB.HEXA.3/8  
109BP  
**REF B=1.68 REF C=1.77**

**1/2" HNPT**



**CGA-1617 REF A 1.76**  
PZA | 109-B TAPON NPT CAB.HEXA.1/2  
109BP  
**REF B=2.68 REF C=2.82**

**1/4"x3/8" KF-PS**



**CGA-2499 REF A 1.62**  
PZA | 203 CONEX.P/MANG.MAC.1/4x3/8 KF-  
PS  
**REF B=2.47 REF C=2.6**

**1/4x1/4"**



**CGA-2505 REF A 1.15**  
PZA | 203 CONEX.P/MANG.MAC.1/4x1/4 KF-  
PS  
**REF B=1.75 REF C=1.84**

**5/16"x1/4" KF-PS**



**CGA-2509 REF A 1.18**  
PZA | 203 CONEX.P/MAN.MACH  
5/16x1/4KF-PS  
**REF B=1.79 REF C=1.89**

**5/16"x3/8" KF-PS**



**CGA-2510 REF A 1.58**  
PZA | 203 CONEX.P/MAN.MAC 5/16x3/8 KF-  
PS  
**REF B=2.4 REF C=2.53**

**3/8"x1/8" ESPxNPT**



**CGA-2516 REF A 0.83**  
PZA | 203 CONEX.MAN/MACH.3/8x1/8  
ESPXNPTM  
**REF B=1.27 REF C=1.34**

**3/8x1/4"**



**CGA-2517 REF A 1.13**  
PZA | 203 CONEX.P/MAN.MACH 3/8x1/4 KF-PS  
**REF B=1.72 REF C=1.81**

**3/8"x3/8" ESPxNPTM**



**CGA-2518 REF A 1.5**  
PZA | 203 CONE.MAN/MACH.3/8X3/8 ESPXNPTM  
**REF B=2.29 REF C=2.41**

**3/8x1/2" ESPxNPTM**



**AQUA PLUS**

**CGA-2520 REF A 1**  
PZA | 203 CONE.MAN/MACH.3/8X1/2 ESPXNPTM  
**REF B=1.53 REF C=1.61**

**1/2"ESP x3/8"NPTM**



**CGA-2522 REF A 1.62**  
PZA | 203 CONEX.P/MANG.1/2x3/8 ESP X NPTM  
**REF B=2.47 REF C=2.6**

**1/2"x1/2" ESPxNPTM**



**AQUA PLUS**

**CGA-2523 REF A 1.09**  
PZA | 203 CONEX.P/MANG.1/2x1/2 ESP X NPTM  
**REF B=1.65 REF C=1.74**

**9/16"x1/4"**



**CGA-2580 REF A 1.76**  
PZA | D01 CONECTOR/MANG.ACETILE.9/16\*1/4  
**REF B=2.68 REF C=2.82**

**9/16"x1/4" D02**



**CGA-2582 REF A 1.76**  
PZA | D02 CONECTOR/MANG.OXIGENO 9/16\*1/4  
**REF B=2.68 REF C=2.82**

**5/16"-206P**



**CGA-2594 REF A 0.76**  
PZA | KF-RM EMPATE P/MANGUERA 5/16 206P  
**REF B=1.16 REF C=1.22**



**CGA-2700 REF A 3.91**  
PZA | BOQUILL.REGULADOR.AIRE P/ QUEMADOR G  
**REF B=5.95 REF C=6.27**

**1/2"**  
**x15M**



**CGA-8000 REF A 3.91**  
PZA | TUBO ROSCABL. 1/2" P/QUEMADOR  
GAS UNV  
**REF B=5.95 REF C=6.27**

**5/16"**  
**x15M**



**CGA-8041 REF A 43.65**  
RLL | TUBO COBR.ACR. 5/16"X50'15,24M  
VT135  
**REF B=66.44 REF C=69.93**

**3/8"**  
**x15M**



**CGA-8047 REF A 64.14**  
RLL | TUBO COBRE ACR. 3/8"X50'15,24M  
VT136  
**REF B=97.63 REF C=102.76**

**1/2"**  
**x15M**

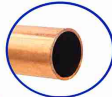

**CGA-8052 REF A 96.22**  
RLL | TUBO COBRE ACR. 1/2"X50'15,24M  
VT137  
**REF B=146.44 REF C=154.14**

**5/8"**  
**x15M**



**CGA-8057 REF A 147**  
RLL | TUBO COBRE ACR. 5/8"X50'15,24M  
VT138  
**REF B=223.73 REF C=235.49**

**3/4"**  
**x15M**



**CGA-8063 REF A 183.53**  
RLL | TUBO COBRE ACR. 3/4"X50'15,24M  
VT139  
**REF B=279.33 REF C=294.01**

**160°- 65Kg**

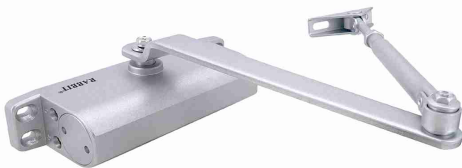

**CYC-2376 REF A 17.23**  
PZA | CIERRAPUERTA HIDRAUL. 65KG  
ALUM. RABB  
**REF B=26.23 REF C=27.61**

**145 PSI**



**DYP-2800 REF A 18.69**  
PZA | BOMBA MANUAL BICI 145 PSI TOTAL  
**REF B=28.44 REF C=29.94**

**1/2"-50M**



**EMT-6180 REF A 17.74**  
RLL | TUBO CORRUG. PLAS. FLEX. NEGRO  
1/2"50MT  
**REF B=27 REF C=28.42**





**Voltage**  
electronics part

**EXT-1092** REF A 10.05  
PZA | EXTEN.MULT.2T.PICO 10A+4USB 2.1A B01  
REF B=15.3 REF C=16.11



**V-TEG**

**EXT-1095** REF A 17.7  
PZA | REGL.ELECTR.6 TOM+4P USB 2.4A 125VTE  
REF B=26.94 REF C=28.36



**V-TEG**

**EXT-1097** REF A 8.95  
PZA | REGLETA-PROTECTOR 3TOM+2 USB VTG/TRO  
REF B=13.62 REF C=14.34



**Voltage**  
electronics part

**EXT-1100** REF A 2.61  
PZA | EXTENS.MULT.PLAS.6TOMA NEGRA GT002B  
REF B=3.97 REF C=4.17



**DIESEL TOOLS**

**EXT-1101** REF A 1.42  
PZA | EXTENSION.MULTIPLE.REGLETA 3TOMA DT  
REF B=2.16 REF C=2.27



**V-TEG**

**EXT-1102** REF A 2.44  
PZA | EXTEN.MULTIPLE.6 TOMAS 10AMP DS 06G  
REF B=3.71 REF C=3.91



**V-TEG**

**EXT-1105** REF A 3.06  
PZA | EXTENS.MULTIP.6 TOMA C/CAB 3MT V882  
REF B=4.65 REF C=4.9



**V-TEG**

**EXT-1107** REF A 3.87  
PZA | EXTENS.MULTIP.6 TOMA C/CAB 5MT V883  
REF B=5.9 REF C=6.21



**V-TEG**

**EXT-1115** REF A 3.67  
PZA | EXTENS.MULTIPLE.CUADRADA 8 TOMAS VTE  
REF B=5.59 REF C=5.89



**2.7M  
125V-9FT**



**EXT-1180 REF A 1.02**  
PZA |EXT.SPT 2X18 C/3T NEGRA 2.7M 9FT  
06  
REF B=1.55 REF C=1.63



**3.65M  
125V-12FT**



**EXT-1183 REF A 1.12**  
PZA |EXT.SPT 2X18 C/3T NEG.3.65M 12FT  
07  
REF B=1.7 REF C=1.79



**4.57M  
125V-15FT**



**EXT-1186 REF A 1.22**  
PZA |EXT.SPT 2X18 C/3T NEG.4.57M 15FT  
08  
REF B=1.86 REF C=1.95



**6M  
125V-20FT**



**EXT-1188 REF A 1.54**  
PZA |EXT.SPT 2X18 C/3T NEG.6.00M 20FT  
09  
REF B=2.34 REF C=2.46



**7.62M  
125V-25FT**



**EXT-1190 REF A 1.74**  
PZA |EXT.SPT 2X18 C/3T NEG.7.62M 25FT  
10  
REF B=2.64 REF C=2.78



**1.80M  
125V-6FT**



**EXT-1200 REF A 0.92**  
PZA |EXT.SPT 2X18 C/3T.POL.1.80M 6FT 99  
REF B=1.4 REF C=1.47



**2.70M  
125V-9FT**



**EXT-1205 REF A 1.02**  
PZA |EXTE.SPT 2X18 C/3T.POL 2.70M 9FT  
00  
REF B=1.55 REF C=1.63



**7.62M  
125V-25FT**



**EXT-1221 REF A 1.74**  
PZA |EXT.SPT 2X18 C/3T POL.7.62M 25FT  
04  
REF B=2.64 REF C=2.78



**9.15M  
125V-30FT**

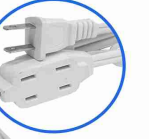

**EXT-1222 REF A 2.04**  
PZA |EXT.SPT 2X18 C/3T POL.9.15M 30FT  
05  
REF B=3.1 REF C=3.26

**3T-2x18**



**EXT-1224** REF A 1.1  
PZA |EXT.DOM.SPT 2x18 C/3T.POL1.8  
6ftFM  
REF B=1.68 REF C=1.77

**2x18-3T  
2.7M**



**EXT-1226** REF A 1.37  
PZA |EXT.DOM.SPT 2x18C/3T.POL 2.7  
9ftFM  
REF B=2.08 REF C=2.19

**2x18-4.6  
3 TOM-15FT**



**EXT-1230** REF A 1.57  
PZA |EXT.DOM.SPT 2x18C/3T.POL4.6  
15ftFM  
REF B=2.39 REF C=2.51

**2x18-3T  
6M**



**EXT-1232** REF A 2.17  
PZA |EXT.DOM.SPT 2x18C/3T.6mt 18ft MXT  
REF B=3.3 REF C=3.48

**1 TOMA  
7.62 M**



**EXT-1234** REF A 14.79  
PZA |EXTENS.S/IND NARJ ST 1T 7.62Mt  
REF B=22.51 REF C=23.69

**1 TOMA  
15.24 M**



**EXT-1236** REF A 22.06  
PZA |EXTEN.S/IND NARJ ST 1T 15.24M 1022  
REF B=33.58 REF C=35.35

**1 TOMA  
30.48 M**



**EXT-1237** REF A 42.01  
PZA |EXTENS.S/IND NARJ ST 1T 30.48Mt  
1224  
REF B=63.94 REF C=67.3

**3 TOMA  
7.62 M**



**EXT-1240** REF A 12.72  
PZA |EXT.NARANJA S/IND C/ST  
3TOM.7.62FM  
REF B=19.35 REF C=20.37

**3 TOMA  
15.24 M**



**EXT-1242** REF A 20.87  
PZA |EXT.NARANJ.S/IND C/ST 3TOM  
15.24FM  
REF B=31.77 REF C=33.44

**3x16-4M**



**EXT-1247** REF A 2.27  
PZA | EXTENSION NARANJA ST 3X16  
3T.4MT DT  
REF B=3.46 REF C=3.64

**3x16-15M**



**EXT-1250** REF A 5.25  
PZA | EXTENSION NARANJA ST 3X16  
3T.15MT D  
REF B=7.99 REF C=8.41

**3x14-4M**



**EXT-1266** REF A 2.96  
PZA | EXTENS.AMARIL.ST 3X14 C/REGL.4  
MT D  
REF B=4.5 REF C=4.74

**3x14-6M**



**EXT-1268** REF A 4.7  
PZA | EXTENS.AMARIL.ST 3X14 C/REGL.6  
MT D  
REF B=7.16 REF C=7.53

**3x14-8M**

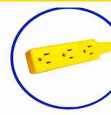

**EXT-1270** REF A 4.48  
PZA | EXTENS.AMARIL.ST 3X14 C/REGL.8  
MT D  
REF B=6.81 REF C=7.17

**3x14-10M**

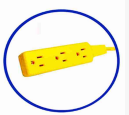

**EXT-1272** REF A 6.48  
PZA | EXTENS.AMARIL.ST 3X14 C/  
REGL.10MT D  
REF B=9.86 REF C=10.38

**4.5MT**



**EXT-1432** REF A 3.39  
PZA | EXT:LAMP.AUX.MECAN P/MET  
AMAR.4.5MT  
REF B=5.16 REF C=5.43

**15.24M**



**EXT-1435** REF A 7.38  
PZA | EXTENS.LAMP.AUX.MECAN PANT/  
MET15.24M  
REF B=11.23 REF C=11.83

**7.62 M**



**EXT-1437** REF A 3.72  
PZA | EXT:LAMP.AUX.MECAN P/MET  
AMAR.7.62M  
REF B=5.67 REF C=5.97



**EXT-1439** REF A 9.24  
 PZA | EXTEN.LAMP.AUX.MECAN PANT/MET 23MT  
 REF B=14.06 REF C=14.79



**EXT-1441** REF A 11.21  
 PZA | EXTEN.LAMP.AUX.MEC.PANT/MET 30.48MT  
 REF B=17.06 REF C=17.95



**EXT-1560** REF A 0.88  
 PZA | EXTENSION TLF.DIG.PLANA P/CAJ 3.65M  
 REF B=1.34 REF C=1.41



**GRI-5397** REF A 1.3  
 PZA | GOMA ESPUMOSA P/DESAGUE WC AQP-827  
 REF B=1.98 REF C=2.09



**GRI-5399** REF A 1.35  
 PZA | GOMA ESPUMOSA P/W.C\*C/TORN.P/TANQ.HTK  
 REF B=2.05 REF C=2.16



**GRI-5401** REF A 3.91  
 PZA | GOMA ESPUMOSA P/DESAGUE WC FP  
 REF B=5.95 REF C=6.26



**GRI-5402** REF A 1.44  
 PZA | EMPACADUR.P/TAPA DE FILTRO CW2/ SP2  
 REF B=2.19 REF C=2.31

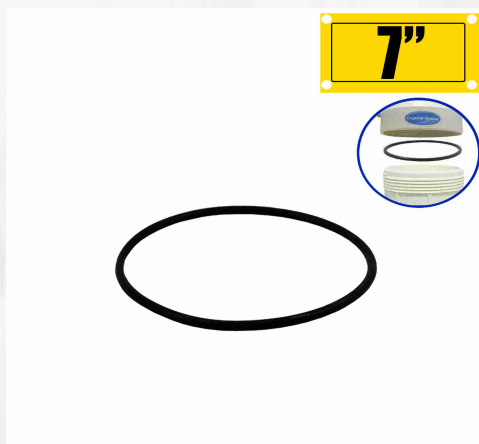

**GRI-5403** REF A 1.44  
 PZA | EMPACADURA, ORING P/TAPA FILTRO 7  
 REF B=2.19 REF C=2.31

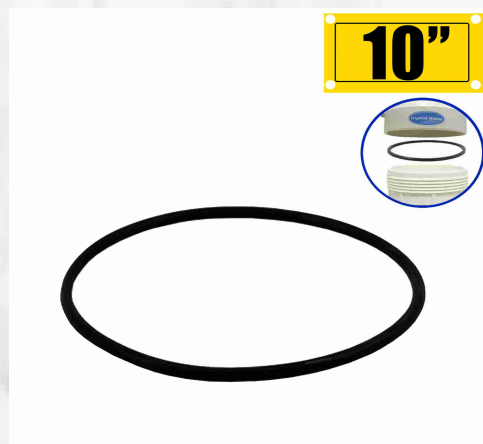

**GRI-5404** REF A 1.44  
 PZA | EMPACADURA, ORING P/TAPA FILTRO 10  
 REF B=2.19 REF C=2.31

**1/4"**



**GRI-5407 REF A 1.44**  
PZA | EMPACADURA P/GRIFERIA CONICA  
1/4"  
REF B=1.59 REF C=1.51



**GRI-5455 REF A 0.29**  
PZA | EMPACAD.SELLO DESAGUE W.C 2040  
REF B=0.45 REF C=0.47

**9"**



**GTE-1290 REF A 0.7**  
PAR | GUANTE TEJIDO/ALGODON C/LATEX  
NS9  
REF B=1.07 REF C=1.12

**9W**



**ILU-2570 REF A 3.46**  
PZA | BOMB.LED RECARGABL.9W A-19 E27  
110V  
REF B=5.26 REF C=5.54

**12W, A-19  
RECARGABLE**



**ILU-2572 REF A 4.33**  
PZA | BOMB.LED RECARGABL.12W A-19 E27  
110  
REF B=6.58 REF C=6.93



**LAM-1595 REF A 8.35**  
PZA | LAMPARA LED EMERGENCIA TRABAJO  
VTEG  
REF B=12.71 REF C=13.38

**63x43  
Cm**



**LIM-0382 REF A 1.77**  
PZA | CUERO GAMUZA LAVAR AUT.63X43  
CHAM05  
REF B=2.69 REF C=2.84



**LIM-5040 REF A 1.54**  
PQT | PAÑOS DE MICRO FIBRA SET 5 PZA  
REF B=2.34 REF C=2.46

**1.5Mts  
12-20mm**



**MAG-2517 REF A 1.9**  
KIT | MANGUER.P/GAS  
3/8"1.5MTS+2ABRAZ.319  
REF B=2.9 REF C=3.05



**1.1/4"x2M**



**AQUA PLUS**

**MAG-3972 REF A 2.24**  
PZA | MANG.DESAG.LAVAD.UNIV.1.1/4X2MT  
020  
**REF B=3.41 REF C=3.58**



**3/4"x1.5M**



**AQUA PLUS**

**MAG-3975 REF A 1.74**  
PZA | MANG.DESAG.LAV.UNIV.3/4X1.5M  
AQP559  
**REF B=2.64 REF C=2.78**



**1/4"x15M**

**MTT**  
Professional Tools

**MAG-6026 REF A 15.14**  
RLL | MANG.1/4"x15Mt P/COMPR.AIRE  
200PSI  
**REF B=23.04 REF C=24.26**



**3CAPAS  
1/4"x30Mts**



**ZASC**

**MAG-6035 REF A 22.8**  
RLL | MANG.PRES.AIRE 300PSI 3C  
1/4X30MT Z  
**REF B=34.69 REF C=36.52**



**3CAPAS  
3/8"x30Mts**



**ZASC**

**MAG-6037 REF A 36.47**  
RLL | MANG.PRES.AIRE 300PSI 3C  
3/8X30MT Z  
**REF B=55.51 REF C=58.43**



**3/8"-200PSI  
60MTS**



**MAG-6054 REF A 4.35**  
MTS | MANG.PRE/AIR-H2O 3/8USA  
200PSIC/60M  
**REF B=6.62 REF C=6.97**



**HSS  
1/8#30**

**Synergy**

**MCH-0025 REF A 0.32**  
PZA | MECHA CALIBR.FPB P/  
REMAC.HSS1/8#30  
**REF B=0.48 REF C=0.5**



**10 PCS  
HSS1/8 #30**

**DIESEL TOOLS**

**MCH-0030 REF A 1.78**  
PQT | MECHA CALIBR.DIES.P/  
REMAC.HSS1/8#30  
**REF B=2.7 REF C=2.84**



**HSS  
5/32#20**

**VINKO**

**MCH-0075 REF A 0.24**  
PZA | MECHA CALIB.FPB P/  
REMAC.HSS5/32#20  
**REF B=0.37 REF C=0.38**



**10 PCS**  
HSS 5/32 #20



**MCH-0080 REF A 2.35**  
PQT |MECH.CALIBR.DIES.P/  
REMAC.HSS5/32#20  
**REF B=3.58 REF C=3.76**



**HSS**  
3/16#11



**MCH-0125 REF A 0.48**  
PZA |MECHA CALIB.FPB P/  
REMAC.HSS3/16#11  
**REF B=0.73 REF C=0.77**



**HSS - 3/16 #11**  
PQT 10 PZAS



**MCH-0130 REF A 3.25**  
PQT |MECH.CALIBR.DIES.P/  
REMAC.HSS3/16#11  
**REF B=4.95 REF C=5.21**

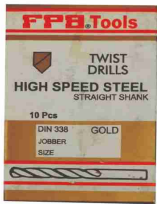

**1/16**



**MCH-0230 REF A 0.11**  
PZA |MECHAS HSS CILIND.FPB DORADA  
1/16  
**REF B=0.16 REF C=0.17**

**3/32"**



**MCH-0275 REF A 0.17**  
PZA |MECHAS HSS DORADA KIEFER 3/32  
**REF B=0.25 REF C=0.26**

**3/32**



**MCH-0280 REF A 0.17**  
PZA |MECHAS HSS CILIND. DORADA 3/32  
**REF B=0.25 REF C=0.26**

**7/64**



**MCH-0300 REF A 0.2**  
PZA |MECHAS HSS DORADA KIEFER 7/64  
**REF B=0.3 REF C=0.31**

**1/8"**



**MCH-0330 REF A 0.2**  
PZA |MECHAS HSS CILIND.FPB DORADA 1/8  
**REF B=0.3 REF C=0.31**

**9/64**



**MCH-0350 REF A 0.21**  
PZA |MECHAS HSS DORADA KIEFER 9/64  
**REF B=0.32 REF C=0.34**



**11/64"**



**MCH-0405 REF A 0.3**  
PZA | MECHAS HSS CILIND.FPB DORADA  
11/64  
**REF B=0.46 REF C=0.48**

**3/16"**



**MCH-0430 REF A 0.33**  
PZA | MECHAS HSS CILIND.FPB DORADA  
3/16  
**REF B=0.5 REF C=0.53**

**13/64"**



**MCH-0455 REF A 0.38**  
PZA | MECHAS HSS CILIND.FPB DORADA  
13/64  
**REF B=0.57 REF C=0.6**

**15/64"**



**MCH-0485 REF A 0.43**  
PZA | MECHAS HSS CILIND. DORADA 15/64  
**REF B=0.66 REF C=0.7**

**9/32"**



**MCH-0550 REF A 0.71**  
PZA | MECHAS HSS DORADA KIEFER 9/32  
**REF B=1.07 REF C=1.13**

**19/64"**



**MCH-0560 REF A 0.75**  
PZA | MECHAS HSS DORADA KIEFER 19/64  
**REF B=1.14 REF C=1.2**

**5/16"**



**MCH-0575 REF A 0.82**  
PZA | MECHAS HSS DORADA KIEFER 5/16  
**REF B=1.24 REF C=1.31**

**5/16"**



**MCH-0580 REF A 0.74**  
PZA | MECHAS HSS CILIND. DORADA 5/16  
**REF B=1.12 REF C=1.18**

**13/32"**



**MCH-0650 REF A 3.28**  
PZA | MECHA HSS DORADA KIEFER 13/32  
**REF B=4.99 REF C=5.25**



**7/16**

**MCH-0680 REF A 1.4**  
PZA | MECHAS HSS CILIND. DORADA 7/16  
REF B=2.12 REF C=2.23



**15/32**

**KIEFER**  
**MCH-0700 REF A 2.65**  
PZA | MECHA HSS DORADA KIEFER 15/32  
REF B=4.03 REF C=4.24



**1/2**

**KIEFER**  
**MCH-0725 REF A 2.37**  
PZA | MECHAS HSS DORADA KIEFER 1/2  
REF B=3.61 REF C=3.8



**7/8 Red a 1/2**

**Eurobit TOOL GROUP ITALY IDEAL QUALITY**  
**MCH-0977 REF A 15.61**  
PZA | MECHA HSS 7/8 RED A 1/2 EUROBIT  
REF B=23.76 REF C=25.01



**8"**

**COBRA TOOLS**  
**MHC-1088 REF A 3.67**  
PZA | ALICATE PINZA PICO LGO. 8" COBRA  
REF B=5.59 REF C=5.89



**COBRA TOOLS**  
**MHC-8463 REF A 4.43**  
JGO | LLAVE ALLEN JGO 9Pz PULG COBRA  
REF B=6.74 REF C=7.09



**COBRA TOOLS**  
**MHC-8466 REF A 4.43**  
JGO | LLAVE ALLEN JGO 9Pza MM COBRA  
REF B=6.74 REF C=7.09



**1/2x18"**

**Q7**  
**MHC-8810 REF A 10.59**  
PZA | PALANCA DE FUERZA DE 1/2"X 18 Q7  
REF B=16.11 REF C=16.96



**1/4"**

**DIESEL TOOLS**  
**MHT-0196 REF A 2.4**  
KIT | ADAPTAD.ACOPL.RAP.MANG/AIRE 5P DIES  
REF B=3.66 REF C=3.85



**5PCS**



**MHT-0198 REF A 2.96**  
KIT | ADAPTAD.ACOPL.RAP.MANG/AIRE 5P  
MAXT

**REF B=4.5 REF C=4.74**



**1/4"-6PCS**



**MHT-0200 REF A 3.74**  
KIT | ADAPTAD.ACOPL RAP.P/MANG.AIRE  
5PZ F

**REF B=5.69 REF C=5.99**

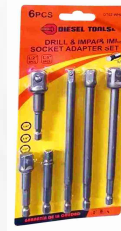

**1/4"**



**MHT-0210 REF A 4.01**  
SET | ADAPTAD.DADO P/TALADR.6PZ 1/4-  
WH006

**REF B=6.1 REF C=6.42**



**1/4"-3/8"  
1/2"**



**MHT-0228 REF A 1.87**  
JGO | ADAPTADOR DADO 4P 1/4-3/8-1/2  
1022

**REF B=2.85 REF C=3**



**1/4"-3/8"  
1/2"**



**MHT-0230 REF A 2.17**  
JGO | ADAPTADOR DADO JGO 4P  
1/4-3/8-1/2Q7

**REF B=3.3 REF C=3.48**



**1/4"-3/8"  
1/2"-3/4"**



**MHT-0233 REF A 9.17**  
JGO | ADAPTAD.DADO JG6 1/4-3/8-1/2-3/4  
DS

**REF B=13.95 REF C=14.69**



**7 PCS  
1/4"-3/8"-1/2"**



**MHT-0234 REF A 8.15**  
JGO | ADAPTAD+CARDAN.SET 7 PC  
UNIVERS.004

**REF B=12.4 REF C=13.06**



**MHT-0325 REF A 0.88**  
PZA | ATOMIZ. PICO ROCIADOR PLAS.S/BOT.

**REF B=1.34 REF C=1.41**



**500ml**



**MHT-0326 REF A 0.7**  
PZA | ATOMIZAD.ROCIADOR C/  
BOT.TRANS.500ML

**REF B=1.07 REF C=1.12**

**500ml**



**DIESEL TOOLS**

**MHT-0328 REF A 0.9**  
PZA | ATOMIZADOR ROCIADOR  
PLAST. 1/2LT500B  
**REF B=1.37 REF C=1.44**

**500cc**



**DIESEL TOOLS**

**MHT-0435 REF A 3.63**  
PZA | ACEITERA P/FLEXIBLE 500CC DIESEL  
TO  
**REF B=5.52 REF C=5.81**

**1.5HP-1 GAL  
60HZ-110V**



**ELITE**

**MHT-0585 REF A 64.29**  
PZA | ASPIRADO.HUM/SEC 1.5HP 3.8 LTS  
ELIT  
**REF B=97.85 REF C=102.99**

**20L  
1100W**



**Jadever**

**MHT-0691 REF A 65.2**  
PZA | ASPIRADO.HUM/SEC 1100W 20 LTS  
R2A20  
**REF B=99.23 REF C=104.45**

**25L  
1100W**



**Jadever**

**MHT-0692 REF A 65.2**  
PZA | ASPIRADO.HUM/SEC 1100W 25 LTS  
R4A25  
**REF B=99.23 REF C=104.45**

**1.2P 30LTS**



**FM  
FERMETAL**

**MHT-0693 REF A 107.08**  
PZA | ASPIRADO.HUM/SEC 1.2P 30 LTS FERM  
**REF B=162.97 REF C=171.54**

**30L  
1100W**



**Jadever**

**MHT-0695 REF A 71.31**  
PZA | ASPIRADO.HUM/SEC 1100W 30 LTS  
R2A30  
**REF B=108.53 REF C=114.24**

**30 L  
1100W**



**Jadever**

**MHT-0697 REF A 77.42**  
PZA | ASPIRADO.HUM/SEC 1100W 30 LTS  
R4A30  
**REF B=117.84 REF C=124.03**

**16GAL**



**RIDGID  
BLOWER**

**MHT-0706 REF A 393.31**  
PZA | ASPIRADORA IND.SEC/HUM RIDGID  
16GAL  
**REF B=598.62 REF C=630.09**



3-4-5-6  
12-16-19mm



**MHT-0786** REF A 5.11  
SET | AVAELLANADORA MAD+MECHA P/  
TAL.7P CW  
REF B=7.78 REF C=8.19

5"



**MHT-1002** REF A 0.87  
PZA |ALICT.PINZA CURVA 5"M/GOMA P/  
BISUTER.  
REF B=1.32 REF C=1.39

5"



**MHT-1004** REF A 0.87  
PZA |ALICT.PINZA PLANA 5"M/GOMA P/  
BISUTER.  
REF B=1.32 REF C=1.39



4 1/2"  
4 PIEZAS



**MHT-1015** REF A 5.71  
SET | ALICATE 4.1/2" MINI JGO  
4Pz.DS10404  
REF B=8.69 REF C=9.15



6"  
6"  
8" PINZA  
PIQUETA  
ALICATE



**MHT-1020** REF A 10.42  
PZA |ALICATES JGO.3P PIN 6-PIQ 6-ALI  
8CROW  
REF B=15.86 REF C=16.69

SACABOCADO  
6 PUNTAS



**MHT-1069** REF A 5.11  
PZA |ALICATE SACABOCADO 6 PUNTAS  
REF B=7.78 REF C=8.19

6"



**MHT-1072** REF A 1.87  
PZA |ALICATE MECANICO COMB.PESD/  
FORRAD 6"  
REF B=2.85 REF C=3

8"



**MHT-1074** REF A 3.24  
PZA |ALICATE MECANICO COMB.CROM. 8"  
REF B=4.93 REF C=5.19

10"



**MHT-1078** REF A 3.54  
PZA |ALICATE MECANICO COMBIN.CROM.  
10"  
REF B=5.39 REF C=5.67



10"



MHT-1079 REF A 3.54  
PZA |ALICATE MECANICO COMB.CRO/  
FORRA.10

REF B=5.39 REF C=5.67



7"



MHT-1082 REF A 2.56  
PZA |ALICAT.PINZ.7"SACA RETEN CERRAR  
REC

REF B=3.89 REF C=4.09



7"



MHT-1083 REF A 2.74  
PZA |ALIC.PINZA.7"SACA RETEN CERRAR  
CURV

REF B=4.17 REF C=4.39



4.1/2"



MHT-1086 REF A 4.43  
PZA |ALICATE PINZA MULTIUSO  
4.1/2"DS2116

REF B=6.74 REF C=7.09



19 EN 1



MHT-1087 REF A 7.52  
PZA |ALIC.PINZA MULTIUSO 6.1/2"19EN1  
269

REF B=11.44 REF C=12.04



8"



MHT-1088 REF A 3.06  
PZA |ALICATE PINZA PIC/RECTO M/GOM  
8"DS

REF B=4.65 REF C=4.9



8"



MHT-1089 REF A 3.23  
PZA |ALICATE PINZA PIC RECTO M/GOM 8  
WQ

REF B=4.92 REF C=5.18



7"



MHT-1093 REF A 10.6  
JGO |ALICATE SACA RETEN 7"JGO 4PCS Q7

REF B=16.14 REF C=16.99



8"



MHT-1099 REF A 2.96  
PZA |ALICATE CORTE DIAGONAL 8" DIESEL  
D8

REF B=4.5 REF C=4.74

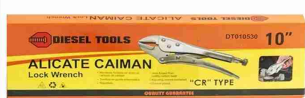

**10"**



**MHT-1102 REF A 2.96**  
PZA |ALICATE DE PRESION RECTO  
10"DT-530

**REF B=4.5 REF C=4.74**



**10"**



**MHT-1104 REF A 5.13**  
PZA |ALICATE DE PRESION ECONOM.DE  
10"DT

**REF B=7.81 REF C=8.22**



**10"**



**MHT-1106 REF A 18.32**  
PZA |ALICATE DE PRESION DE 10" VISE-GRIP

**REF B=27.88 REF C=29.35**



**10"**  
MANGO DE GOMA



**MHT-1108 REF A 4.69**  
PZA |ALICATE PRESION RECT.10 M/GOM  
DIES

**REF B=7.14 REF C=7.52**



**10"**



**MHT-1109 REF A 3.94**  
PZA |ALICAT.PRESIO.RECT.10"M/GOM MAX-  
T10

**REF B=6 REF C=6.31**



**MHT-1156 REF A 2.21**  
PAR |BORNES ALUMINIO + Y - P/CARRO JGO

**REF B=3.36 REF C=3.53**



**MHT-1158 REF A 0.72**  
PAR |BORNE COBRE CARRO + Y N PAR MAX  
074

**REF B=1.09 REF C=1.15**



**MHT-1160 REF A 2.57**  
PZA |BORNES D/PLOMO P/CARRO

**REF B=3.92 REF C=4.12**



**10 PCS**



**MHT-1161 REF A 7.89**  
SET |BORNES D/PLOMO CARRO PQT 10PZ  
DIESEL

**REF B=12.01 REF C=12.65**



**MHT-1162** REF A 2.94  
PAR | BORNES BRONC CARR ACODAD.(+)-2Pz

REF B=4.47 REF C=4.71



**MHT-1163** REF A 1.71  
PZA | BORNES D/PLOMO MARIPOSA POSITIVO

REF B=2.6 REF C=2.73



**MHT-1164** REF A 1.71  
PZA | BORNES D/PLOMO MARIPOSA NEGATIVO

REF B=2.6 REF C=2.73



**MHT-1260** REF A 3.31  
PZA | BOMBA P/TAMBOR PLASTICA 1" DS-S210

REF B=5.03 REF C=5.3



**MHT-1264** REF A 24.45  
PZA | BOMB.TAMBOR MET.ACEIT.15L/MIN 2515

REF B=37.21 REF C=39.17



**MHT-1265** REF A 36.23  
PZA | BT-25 BOMBA PARA TAMBOR ROTATIVA 1"

REF B=55.15 REF C=58.05



**MHT-1360** REF A 2.27  
PZA | BOQUILLA P/SOPLAR 5PCS 1/4NPT DN005

REF B=3.46 REF C=3.64



**MHT-1500** REF A 1.62  
PZA | CALIBRADOR PLASTICO 6" DIESEL IMP

REF B=2.46 REF C=2.59



**MHT-1501** REF A 5.81  
PZA | CALIBRADOR.VERNIER ACER/INOX 6"150M

REF B=8.85 REF C=9.31





**1.00mm**

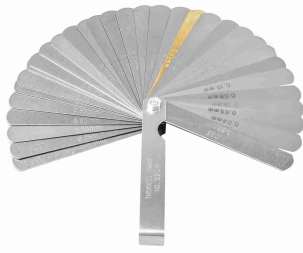

**MHT-1507 REF A 3.31**

PZA | CALIBRAD.VALV/BUJIAS  
32H.0.03-1.00M

REF B=5.03 REF C=5.3



**60W-110V**



**MHT-2013 REF A 2.24**

PZA | CAUTIN PUNTA FINA 60W 110V SEA  
053

REF B=3.41 REF C=3.58



**60W-110V**



**MHT-2014 REF A 3.16**

PZA | CAUTIN PUNTA FINA 60W 110V  
VOLTAGE

REF B=4.8 REF C=5.06



**110v-60w**



**MHT-2015 REF A 3.92**

PZA | CAUTIN PUNTA FINA 60W 110V  
Q7-3001

REF B=5.97 REF C=6.29



**MHT-2107 REF A 1.19**

PZA | CEPIL.ALAMBRE 5H.M/  
PLAS.ERGONOM.169

REF B=1.8 REF C=1.9



**MHT-2108 REF A 1.19**

PZA | CEPIL.ALAMBR.5H.M/  
PLAS.ERG.BRON.170

REF B=1.8 REF C=1.9

**4 HILERAS  
DE CERDAS**



**MHT-2109 REF A 0.7**

PZA | CEPILLO ALAMBRE 4 HILERA CABO  
MADERA

REF B=1.07 REF C=1.12

**6 HILERA**



**MHT-2111 REF A 0.78**

PZA | CEPILLO ALAMBRE C/MADERA 6 HIL

REF B=1.19 REF C=1.26

**5 HILERA**



**MHT-2112 REF A 0.5**

PZA | CEPILLO ALAMBRE C/MADERA 5  
HILERA

REF B=0.76 REF C=0.8



**MAXI TOOLS**

MHT-2113 REF A 1.57  
BLI | CEPILLO ALAMBRE 4PZ.SURTIDOS  
MAX004  
REF B=2.39 REF C=2.51



**DIESEL TOOLS**

MHT-2114 REF A 1.87  
BLI | CEPILLO ALAMBRE PEQ.METAL 3 PZA  
IMP  
REF B=2.85 REF C=3



**DIESEL TOOLS**

MHT-2116 REF A 0.78  
PZA | CEPILLO ALAMBRE C/PLAST.4X16  
DIE723  
REF B=1.19 REF C=1.26



**4 PELOS  
14 LINEAS**

MHT-2117 REF A 0.62  
PZA | CEPILL.ALAMBRE C/PLAST.4X14  
PH-502S  
REF B=0.94 REF C=0.99



**6 PELOS  
16 LINEAS**

MHT-2118 REF A 0.53  
PZA | CEPILL.ALAMB.LATONAD.C/  
PLAS.6X16 IMP  
REF B=0.81 REF C=0.86



**4PCS**

MHT-2121 REF A 1.39  
BLI | CEPILLO ALAMBRE 4 TAMAÑOS DS-  
LF004  
REF B=2.11 REF C=2.22



**24.5mm**

MHT-2122 REF A 4.89  
PZA | CEPILLO MINI 25.4mm CARPINTERO  
COVO  
REF B=7.44 REF C=7.83



**3"x5/8"**

**MAXI TOOLS**

MHT-2124 REF A 1.09  
PZA | CEPILLO TAZA TRENZADO 3"x5/8"  
MX833  
REF B=1.65 REF C=1.74



**5/8x5"**

**STRUGGER  
HEAVY DUTY TOOLS**

MHT-2129 REF A 14.99  
PZA | CEPIL.TAZA TRENZADO  
5X5/8"STRUGGER  
REF B=22.82 REF C=24.02



5"x14mm



MHT-2130 REF A 22.65  
PZA | CEPIL.TAZA TRENZADO 5X14M  
STRUGGER

REF B=34.48 REF C=36.29



5x5/8"



MHT-2131 REF A 4.61  
PZA | CEPILLO TAZA TRENZADO 5"x5/8"IMP

REF B=7.02 REF C=7.38



5x5/8"



MHT-2132 REF A 2.76  
PZA | CEPILLO TAZA TRENZADO 5"x5/8"  
MX835

REF B=4.19 REF C=4.41



MHT-2133 REF A 1.57  
SET | CEPILL.COPA/BROCH.P/TALAD.3Pz  
WOLFS1

REF B=2.39 REF C=2.51



MHT-2134 REF A 1.77  
JGO | CEPILL.COPA/BROCHA P/TALAD.3P  
DS024

REF B=2.69 REF C=2.84



MHT-2135 REF A 2.45  
JGO | CEPILLO COPA/BROCHA P/TALADRO  
3P Q7

REF B=3.74 REF C=3.93



1/4"



MHT-2136 REF A 1.47  
JGO | CEPILLO COPA/BROCHA P/TALAD.3P  
MAXIT

REF B=2.24 REF C=2.35



1/2, 5/8, 1"

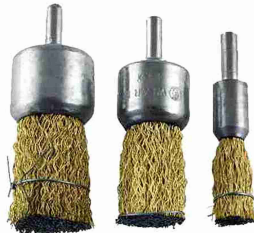

MHT-2137 REF A 1.39  
JGO | CEPILLO T/BROCHA P/TALADRO 3  
PZA DT

REF B=2.12 REF C=2.23



2x1/4"

MHT-2139 REF A 2.01  
PZA | CEPILLO COPA ALAMBRE 2 X 1/4" IMP

REF B=3.06 REF C=3.22

**3x1/4"**



**MHT-2140 REF A 1.77**  
PZA | CEPIL. COPA  
TALADR. TRENZ. 3X1/4" WB3-3  
**REF B=2.69 REF C=2.84**



**3"**



**MHT-2141 REF A 1.09**  
PZA | CEPILLO COPA TALADRO 3X1/4" WF-  
B23  
**REF B=1.65 REF C=1.74**



**3"x1/4"**



**ZASC**

**MHT-2142 REF A 1.47**  
PZA | CEPILLO COPA ALAMBRE 3"X 1/4"  
ZASC  
**REF B=2.24 REF C=2.35**



**2"x1/4"**



**ZASC**

**MHT-2144 REF A 1.04**  
PZA | CEPILLO CIRCULAR 2 X 1/4" ZASC BC2  
**REF B=1.58 REF C=1.66**



**3"x1/4"**



**ZASC**

**MHT-2145 REF A 1.12**  
PZA | CEPILLO CIRCULAR 3 X 1/4" ZASC BC3  
**REF B=1.7 REF C=1.79**



**8Pcs**



**MHT-2147 REF A 2.37**  
JGO | CEPILLO CIRCULAR P/TALAD. 8Pz  
WFBS-3  
**REF B=3.61 REF C=3.8**



**6PCS**



**MHT-2148 REF A 4.14**  
JGO | CEPIL. ALAMB. MANUAL-CIRC. P/TALD  
6pDT  
**REF B=6.3 REF C=6.63**



**5PCS**



**MHT-2149 REF A 1.97**  
JGO | CEPILLO CIRCULAR P/TALDR. JGO 5pz  
DI  
**REF B=3 REF C=3.16**



**MHT-2159 REF A 2.86**  
JGO | CEPILLO/CIRCUL. Y COPA P/TALD 5P  
WOLG  
**REF B=4.35 REF C=4.57**



**1/2"**



**MHT-2172 REF A 0.78**  
PZA | CEPILLO T/BROCH.C/  
ESP.TALAD.1/4X1/2  
**REF B=1.19 REF C=1.26**



**1/4x3/4"**



**MHT-2173 REF A 0.78**  
PZA | CEPILLO T/BROCH.C/  
ESP.TALAD.1/4"X3/4  
**REF B=1.19 REF C=1.26**



**1/4"x1"**



**MHT-2175 REF A 1**  
PZA | CEPILLO T/BROCH.C/  
ESP.TALAD.1/4"X1"  
**REF B=1.53 REF C=1.61**



**1/4x1"**



**MHT-2176 REF A 0.59**  
PZA | CEPILLO T/BROCH.C/  
ESP.TALAD.1/4"X1"  
**REF B=0.89 REF C=0.94**



**MHT-2179 REF A 1.19**  
PZA | CEPILLO MANUAL ALAMB.16M C/  
PLAS.SEAL  
**REF B=1.8 REF C=1.9**



**4 CIFRAS**

**MHT-2361 REF A 6.69**  
PZA | CUENTA PIEZA DE 4 CIFRAS  
**REF B=10.18 REF C=10.71**



**3 TON  
x4mm**



**MHT-2363 REF A 7.46**  
PZA | CUERDA DE ARRASTRE 3TON X4MM  
CROWNM  
**REF B=11.35 REF C=11.95**



**18-24-32  
40"x8mm**



**MHT-2365 REF A 3.16**  
PQT | CUERDA ELAST.18/24/32/40"X8MM  
8PZA  
**REF B=4.8 REF C=5.06**



**8mm  
x80cm**



**MHT-2366 REF A 1.57**  
PAR | CUERDA ELASTICA 8MMX80CM  
CROWNM  
**REF B=2.39 REF C=2.51**



48"-120cm



MHT-2368 REF A 0.9  
PZA | CUERDA ELASTICA EQUIPAJE 120CM 2018

REF B=1.37 REF C=1.44



12x180 cm



MHT-2370 REF A 2.35  
PZA | CUERDA ELASTICA 12MMX180CM CROWNMAN

REF B=3.58 REF C=3.77

36"



MHT-2389 REF A 1.2  
PZA | CUERDA ELASTICA 36"

REF B=1.83 REF C=1.93



1/8"-7/8"



MHT-2405 REF A 6.66  
PZA | CORTATUBO MINI 1/8 A 7/8 URSO

REF B=10.14 REF C=10.67



MHT-2417 REF A 1.19  
PZA | CORTA VIDRIO ECONOMICO ALEMAN DIES

REF B=1.8 REF C=1.9



6"



MHT-2460 REF A 1.87  
BLT | COR.TODO MET.PLEGABLE 6" C/ REP.817

REF B=2.85 REF C=3



MHT-2464 REF A 1.87  
KIT | CORTA PRECISION T/LAPIZ 13Pza DT203

REF B=2.85 REF C=3



3PCS



MHT-2467 REF A 1.96  
BLS | CORTA TODO PLAS.3Pz HUNT HM-1450

REF B=2.98 REF C=3.13



6"



MHT-2475 REF A 2.35  
PZA | CORTA TODO MET.6" HUNT/URS HM-1184

REF B=3.58 REF C=3.77

**3"**  
53-157mm



**MHT-2494** REF A 3.92  
PZA | COMPRESOR P/ANILLO PISTON  
3"D-53-175MM  
REF B=5.97 REF C=6.29

**4"**  
53-157mm



**MHT-2495** REF A 4.43  
PZA | COMPRESOR P/ANILLO PISTON  
4"D-53-175MM  
REF B=6.74 REF C=7.09

**6"**  
60-195mm



**PROFESIONAL  
TOOL**

**MHT-2496** REF A 7.13  
PZA | COMPRESOR P/ANILLO PISTON  
6"D-60-195MM  
REF B=10.86 REF C=11.43

**3"**



**DIESEL TOOLS**

**MHT-2497** REF A 3.31  
PZA | COMPRESOR P/ANILLO PISTON  
3"D-303A3  
REF B=5.03 REF C=5.3

**4"**



**DIESEL TOOLS**

**MHT-2498** REF A 3.91  
PZA | COMPRESOR P/ANILLO PISTON  
4"DS303A4  
REF B=5.95 REF C=6.26

**6"**



**DIESEL TOOLS**

**MHT-2499** REF A 6.84  
PZA | COMPRESOR P/ANILLO PISTON  
6"D-303A6  
REF B=10.41 REF C=10.96

**5/16"**



**Q7**

**MHT-2914** REF A 2.17  
KIT | DADO MAGNETI.5/16 P/  
TORN.TECH.5P Q7  
REF B=3.3 REF C=3.48

**12PCS**



**CROWNMAN  
PROFESSIONAL**

**MHT-2950** REF A 17.7  
PZA | DADO TARRAJA JGO 12PCS  
CROWNMAN  
REF B=26.94 REF C=28.36

**12P  
3-12mm**



**MHT-2952** REF A 8.65  
SET | DADO TARRAJA Y MACHO JGO 12P  
3-12MM  
REF B=13.17 REF C=13.86



**6PCS**



**MHT-3176 REF A 1.67**  
SET | DESTORNILLAD.PRECISION JGO 6 PZ 707  
**REF B=2.54 REF C=2.68**



**Nº1 - Nº2**  
1.4 - 2.0 mm  
2.4 - 3.0 mm



**MHT-3178 REF A 0.78**  
PZA | DESTORNILLADOR PRECISION JOYERO.JGO  
**REF B=1.19 REF C=1.26**



**T5-T6-T7**  
**T8-T9-T10**



**MHT-3181 REF A 1.2**  
SET | DESTORNIL.PRECISION TORX JOYER.406  
**REF B=1.83 REF C=1.93**



**1/8x4"**



**MHT-3188 REF A 1.01**  
PZA | DESTORN.PLANO VINKO AZUL 1/8 X 4  
**REF B=1.54 REF C=1.62**



**3/16x6"**



**MHT-3192 REF A 1.63**  
PZA | DESTORN.PLANO VINKO AZUL 3/16 X 6  
**REF B=2.48 REF C=2.61**



**3/16x8"**



**MHT-3194 REF A 1.69**  
PZA | DESTORN.PLANO VINKO AZUL 3/16 X 8  
**REF B=2.57 REF C=2.71**



**1/4x6"**



**MHT-3198 REF A 0.97**  
PZA | DESTORN.PLANO VINKO AZUL 1/4 X 6  
**REF B=1.47 REF C=1.55**



**5/16x6"**



**MHT-3200 REF A 2.03**  
PZA | DESTORN.PLANO VINKO AZUL 5/16 X 6  
**REF B=3.09 REF C=3.25**



**3/16x10"**



**MHT-3280 REF A 0.58**  
PZA | DESTORN.ESTRIA DIESEL TOO.3/16 X 10  
**REF B=0.89 REF C=0.94**





**3/16x12**

**MHT-3281 REF A 0.67**  
 PZA | DESTORN. ESTRIA DIESEL TOO. 3/16 X 12  
**REF B=1.02 REF C=1.07**



**PH2-10PCS**

**MHT-3301 REF A 1.5**  
 SET | DES: PUNTA ESTR. #2 DRYWAL JG10Pz-010  
**REF B=2.29 REF C=2.41**



**1/4x2"**

**MHT-3303 REF A 1.32**  
 PQT | DES.: PUNTA ESTRIA #2 1/4X2 10PC 001  
**REF B=2.01 REF C=2.11**



**2x1/4"**

**MHT-3307 REF A 0.55**  
 PZA | DES: PUNTA ESTR. #2 LARG 2 \* 1/4 USA  
**REF B=0.84 REF C=0.88**



**T5, T6, T7, T8 PH0, PH1, PH2**

∅ 2.0 ∅ 3.0

**MHT-3315 REF A 1.77**  
 SET | DESTORNILLA. INTERCAMBIABLE 9EN1 326  
**REF B=2.69 REF C=2.84**



**6PCS**

**MHT-4210 REF A 4.84**  
 JGO | DESTORNILLAD. ECON.T/STANLEY 6PJGO  
**REF B=7.37 REF C=7.76**



**10PCS**

**MHT-4212 REF A 11.73**  
 JGO | DESTORN. ROJ/AZ.P/MANG 10P HM1652  
**REF B=17.85 REF C=18.79**



**10pcs**

**MHT-4213 REF A 6.51**  
 JGO | DESTORNILLAD. JGO 10PC PUNT/ MAGN 202  
**REF B=9.91 REF C=10.43**



**6PCS**

**MHT-4214 REF A 13.49**  
 JGO | DESTORN. M/ERGO.P/MANG. 6PZA HM-1309  
**REF B=20.54 REF C=21.62**

**22PCS**



**Maxtools**

**MHT-4216 REF A 6.93**  
PZA | DESTORNIL. JUEGO 22 PZA  
MAXTOOL/280  
**REF B=10.55 REF C=11.1**

**20PCS**



**POWER PRO CRAFT**

**MHT-4217 REF A 6.93**  
PZA | DESTORNIL. JUEG 20P POWERCRAFT  
SD20S  
**REF B=10.55 REF C=11.1**

**4PCS  
1000V**



**CROWNMAN PROFESSIONAL**

**MHT-4220 REF A 7.48**  
PZA | DESTOR. JGO 4P ELECTRICISTA 1000V  
CRO  
**REF B=11.39 REF C=11.99**

**1/2"  
8mm**



**DIESEL TOOLS**

**MHT-4250 REF A 7.88**  
PZA | DESTORNILLADOR IMPACTO 1/2X8M  
DIEST  
**REF B=12 REF C=12.63**

**7"**



**MHT-4344 REF A 3.23**  
PZA | DISC. RESPALD. PLAS/NYLON  
7"8500RPM  
**REF B=4.92 REF C=5.17**

**7"**



**MHT-4347 REF A 5**  
PZA | DISC. RESPALDO GOMA SIN/TC 7"P/  
PULIR  
**REF B=7.61 REF C=8.01**

**7"**



**Wolfgang**

**MHT-4348 REF A 4.54**  
PZA | DISCO RESPALDO DE GOMA P/PULIR 7"  
**REF B=6.91 REF C=7.28**

**4.1/2"**



**DIESEL TOOLS**

**MHT-4350 REF A 1.52**  
PZA | DISCO DE GOMA 4.1/2"P/ESMERIL  
DIESEL  
**REF B=2.32 REF C=2.44**

**4.1/2"**



**Q7**

**MHT-4351 REF A 1.52**  
PZA | DISC. GOMA 4.1/2" P/ESMER. C/T 5/8  
Q7  
**REF B=2.31 REF C=2.43**



7"



MHT-4352 REF A 2.72  
PZA | DISCO DE GOMA 7"P/ESMERIL DIESEL

REF B=4.14 REF C=4.36



7"



MHT-4353 REF A 2.96  
PZA | DISCO GOMA 7" P/ESMERIL C/T 5/8" Q7

REF B=4.5 REF C=4.74



12mm  
3/8"



MHT-5410 REF A 0.7  
CJA | GRAPA METAL PLANA 12MM 3/8 1000P CR

REF B=1.07 REF C=1.12



400cc



MHT-5413 REF A 10.5  
PZA | ENGRASADORA MANUAL 400 CC.

REF B=15.97 REF C=16.81



8L



MHT-5418 REF A 50.94  
PZA | ENGRASADORA MANUAL 8LT ALT/ PRES.CROW

REF B=77.52 REF C=81.6



16 L



MHT-5420 REF A 48.53  
PZA | ENGRASADORA MANUAL 20KG DIESE GP016

REF B=73.86 REF C=77.74



1/8"-3/4"



MHT-5452 REF A 1.74  
JGO | EXTRAC.P/TORNILLO ROTOS 5PZ 1/8-3/4

REF B=2.64 REF C=2.78



MHT-5454 REF A 7.67  
JGO | EXTRACTOR DE POLEA DIESEL BP01

REF B=11.67 REF C=12.28



2"a 8"



MHT-5455 REF A 27.05  
PZA | EXTRACTOR 2 MORDAZAS 2"A8"DIES 0640

REF B=41.18 REF C=43.34



**DIESEL TOOLS**

**MHT-5457 REF A 13.96**  
PZA |EXTRACTOR IMPACT.INYECTOR  
DIESE.617  
**REF B=21.25 REF C=22.37**



**3"**



**CROWNMAN®**

**MHT-5468 REF A 4.93**  
PZA |EXTRACTOR D/POLEA 3 BRAZO 3"  
CROWNA  
**REF B=7.5 REF C=7.89**



**4"**



**CROWNMAN®**

**MHT-5469 REF A 7.53**  
PZA |EXTRACTOR D/POLEA 3 BRAZO 4  
CROWNMA  
**REF B=11.46 REF C=12.07**



**6"**

**CROWNMAN®**

**MHT-5471 REF A 14.26**  
PZA |EXTRACTOR D/POLEA 3 BRAZO 6  
CROWNMA  
**REF B=21.71 REF C=22.85**



**DIESEL TOOLS**



**MHT-6110 REF A 3.94**  
PZA |ESTETOSCOPIO DE CILINDRO P/AUTO  
DT  
**REF B=6 REF C=6.31**



**2"-3"-4"**

**SPLACA®**

**MHT-6470 REF A 1.45**  
JGO |ESPAT.PLAST.C/MANG PLAST2,3,4  
SPLA  
**REF B=2.21 REF C=2.33**



**RIDGID**

**MHT-6517 REF A 48.07**  
PZA |FILTRO STANDARD P/ASPIRADORA  
RIDGID  
**REF B=73.16 REF C=77.01**



**2 Toneladas  
Tipo A**

**MHT-7588 REF A 13.38**  
PZA |GATO BOTELLA DE 2 TONELADAS  
TIPO A  
**REF B=20.36 REF C=21.43**



**4 Toneladas  
Tipo A**

**MHT-7594 REF A 17.63**  
PZA |GATO BOTELLA DE 4 TONELAD.TIPO A  
**REF B=26.83 REF C=28.24**

**8"****DIESEL TOOLS**

**MHT-7604 REF A 27.5**  
 PZA |GATO BOTELLA DE 8 TONELADAS  
 DS1685  
**REF B=41.86 REF C=44.06**

**10 TON****FM FERMETAL**

**MHT-7617 REF A 25.35**  
 PZA |GATO BOTELLA DE 10  
 TONELAD.IMPORT  
**REF B=38.58 REF C=40.61**

**12 TON****FM FERMETAL**

**MHT-7620 REF A 48.14**  
 PZA |GATO BOTELLA DE 12 TONELADA  
 IMPORT  
**REF B=73.27 REF C=77.12**

**20 TON****FM FERMETAL**

**MHT-7633 REF A 39.08**  
 PZA |GATO BOTELLA DE 20  
 TONELADA.IMPORT  
**REF B=59.48 REF C=62.6**

**30 TON****FM FERMETAL**

**MHT-7635 REF A 159.29**  
 PZA |GATO BOTELLA DE 30  
 TONELADA.IMPORT  
**REF B=242.44 REF C=255.18**

**50 TON****FM FERMETAL**

**MHT-7637 REF A 204.76**  
 PZA |GATO BOTELLA DE 50  
 TONELADA.IMPORT  
**REF B=311.64 REF C=328.02**

**1.5TON****DIESEL TOOLS**

**MHT-7642 REF A 14.78**  
 PZA |GATO MECANICO TIJERA 1.5TON  
 DT-2105  
**REF B=22.49 REF C=23.68**

**2TON****DIESEL TOOLS**

**MHT-7645 REF A 19.71**  
 PZA |GATO MECANICO TIJERA 2.0TON  
 DS-2106  
**REF B=29.99 REF C=31.57**

**2 TON****DIESEL TOOLS**

**MHT-7648 REF A 33.07**  
 PZA |GATO CAIMAN 2 TON.T/A C/  
 ESTUCH.DT01  
**REF B=50.33 REF C=52.97**



**2TON-12V**

MHT-7649 REF A 63.91  
 PZA |GATO TIJERA 2TON.ELECTRICO 12V  
 DIES  
 REF B=97.27 REF C=102.39



**2.1/2 TON**



MHT-7651 REF A 183.85  
 PZA |GATO CAIMAN DE 2.1/2 TONELADA  
 FMT  
 REF B=279.82 REF C=294.53



**3 TON**



MHT-7653 REF A 127.81  
 PZA |GATO CAIMAN DE 3 TON. MAXITOLS  
 REF B=194.52 REF C=204.74



**10 TON**

MHT-7655 REF A 229.61  
 PZA |GATO POWER DE 10 TON FERMETAL  
 REF B=349.47 REF C=367.84



**500KG  
1.90MTS**



MHT-7658 REF A 133.7  
 PZA |GATO TRANSMISI.HIDRAUL.500K  
 1.90ALT  
 REF B=203.49 REF C=214.19



**1 TON**



MHT-7660 REF A 670.1  
 PZA |GATO TRANSMISION HIDRAUL.1 TON  
 MEGA  
 REF B=1019.89 REF C=1073.5



**2 TON**



MHT-7663 REF A 486.48  
 PZA |GRUA MOTOR TELESCOPICA 2  
 TONELADA  
 REF B=740.42 REF C=779.34



**5 PCS**



MHT-7710 REF A 1.51  
 KIT | HOJA P/SIERRA CALADORA 5P TRIS/  
 VINK  
 REF B=2.3 REF C=2.43



**18DIENTES  
12"**



MHT-7785 REF A 40.31  
 BLT | HOJA SEGUETA BLA/BIMET.18D B/50P  
 DT  
 REF B=61.36 REF C=64.58



**18 Dientes**

**MHT-7790 REF A 1.41**  
 PZA |HOJA P/SEGUETA BLANCA LENOX DE 18D  
**REF B=2.15 REF C=2.26**



**24 Dientes**

**MHT-7800 REF A 1.41**  
 PZA |HOJA P/SEGUETA BLANCA LENOX DE 24D  
**REF B=2.15 REF C=2.26**



**1600PSI 1400W-5.1L**

**ZASC**  
**MHT-7944 REF A 115.63**  
 PZA |HIDROLAVAD.1600PS.5.1L/ MIN.MAG.5M Z  
**REF B=175.99 REF C=185.24**



**3HP-2000PSI 13LTS-110V**

**MHT-7947 REF A 203.74**  
 PZA |HIDROLAVA.3HP 2000PSI 13L/M 110V Q7  
**REF B=310.09 REF C=326.39**



**1/4 NPT**

**MHT-7960 REF A 1.18**  
 PZA |INFLADOR PICO AIRE CAUCHO 1/4 DS545  
**REF B=1.8 REF C=1.89**



**1/4"**

**MHT-7965 REF A 1.64**  
 PZA |INFLADOR CAUCH.CARRO-CAMION 1/4"04B  
**REF B=2.49 REF C=2.62**



**#3 160Gr**

**MHT-8347 REF A 1.1**  
 PZA |LANA ACERO GRADO 3 IMP 160 Grs 320  
**REF B=1.68 REF C=1.77**



**#3-400Gr**

**MHT-8348 REF A 2.45**  
 PZA |LANA ACERO GRADO 3 IMP 400Gs DIESEL  
**REF B=3.74 REF C=3.93**



**#5-160Gr**

**MHT-8350 REF A 1.27**  
 PZA |LANA ACER.GRAD 5 IMP 160Gr ANAB/DIES  
**REF B=1.93 REF C=2.03**



**#5**  
**400Gr**

**MHT-8355 REF A 2.66**  
PZA |LANA ACER GRAD 5 IMP 400GrS AN/  
DIES  
**REF B=4.04 REF C=4.25**



**10-19mm**

**MHT-8404 REF A 22.66**  
SET | LLAV C/RATCH.FIJ 7PZA 10-19M DS  
R07  
**REF B=34.49 REF C=36.3**



**13/16"**

**MHT-8411 REF A 2.35**  
PZA | LLAVE D/BUJIA.TIP/T.13/16"MAN/AISL  
**REF B=3.58 REF C=3.77**



**3 en 1**  
**5/16, 1/2, 9/16, 7/8"**

**MHT-8427 REF A 6.88**  
PZA |LLAV.COMB.MUL/USO 3EN1 MM-PLG-  
TORX  
**REF B=10.47 REF C=11.02**



**6"**

**MHT-8428 REF A 2.54**  
PZA |LLAVE AJUSTABLE CROM.6" C/BLIS.IMP  
**REF B=3.86 REF C=4.07**



**8"**

**MHT-8429 REF A 2.86**  
PZA |LLAVE AJUSTABLE CROM. 8"C/BLIS.IMP  
**REF B=4.35 REF C=4.57**



**10"**

**MHT-8431 REF A 3.44**  
PZA |LLAVE AJUSTABLE CROM.10"C/BLIS.IMP  
**REF B=5.24 REF C=5.51**



**12"**

**MHT-8433 REF A 4.61**  
PZA |LLAVE AJUSTABLE CROM.12"C/BLIS.IMP  
**REF B=7.02 REF C=7.38**



**15"**

**MHT-8435 REF A 9.34**  
PZA |LLAVE AJUSTABLE CROM.15"C/BLIS.IMP  
**REF B=14.21 REF C=14.96**



**11PCS  
[1/4B-3/4B]**



**UDUKE**

**MHT-8437 REF A 10.22**  
JGO | LLAVE COMB CR/VND JG 11P 1/4-3/4  
UD  
REF B=15.56 REF C=16.37

**11PCS  
[6-19 MM]**



**UDUKE**

**MHT-8438 REF A 10.22**  
JGO | LLAVE COMB CR/VND JGO 11P 6-19MM  
UDE  
REF B=15.56 REF C=16.37

**1/4"  
A 13/16"**



**UDUKE**

**MHT-8439 REF A 14.75**  
JGO | LLAVE COMB CR/VND JG 14Pz  
1/4-13/16  
REF B=22.44 REF C=23.62

**6-21MM**



**UDUKE**

**MHT-8440 REF A 14.75**  
JGO | LLAVE COMB CR/VND JG 14Pz 6-21M  
UDE  
REF B=22.44 REF C=23.62

**1/4-7/8"  
8-18MM**



**UDUKE**

**MHT-8441 REF A 25.17**  
JGO | LLAV.COMB C/V JG 22P 1/4-7/8-8-18M  
REF B=38.3 REF C=40.32

**1/4"**



**UDUKE**

**MHT-8442 REF A 0.7**  
PZA | LLAVE COMB.CR/VANAD PROF.1/4"  
UDEKE  
REF B=1.07 REF C=1.12

**5/16**



**UDUKE**

**MHT-8444 REF A 0.73**  
PZA | LLAVE COMB.CR/VANAD PROF.5/16  
UDEKE  
REF B=1.12 REF C=1.18

**3/8**



**UDUKE**

**MHT-8446 REF A 0.78**  
PZA | LLAVE COMB.CR/VANA T/ACESA  
3/8"UDEK  
REF B=1.19 REF C=1.26

**7/16**



**UDUKE**

**MHT-8447 REF A 0.78**  
PZA | LLAVE COMB.CR/VANA T/ACES  
7/16  
UDEK  
REF B=1.19 REF C=1.26



**1/2**



**MHT-8448 REF A 1.1**  
PZA |LLAVE COMB.CR/VANAD T/ACESA  
1/2"UDE  
**REF B=1.68 REF C=1.77**



**9/16"**



**MHT-8450 REF A 1.1**  
PZA |LLAVE COMB.CR/VANAD T/ACES  
9/16 UD  
**REF B=1.68 REF C=1.77**



**5/8"**



**MHT-8452 REF A 3.6**  
PZA |LLAVE COMBINAD CR/VANAD T/ACES  
5/8  
**REF B=5.48 REF C=5.77**



**11/16"**



**MHT-8454 REF A 3.68**  
PZA |LLAVE COMBIN.CR/VANAD PROTUL  
11/16  
**REF B=5.59 REF C=5.89**



**3/4"**



**MHT-8456 REF A 1.77**  
PZA |LLAVE COMB.CR/VANAD T/  
ACES.3/4"UDEK  
**REF B=2.69 REF C=2.84**



**13/16"**



**MHT-8457 REF A 5.72**  
PZA |LLAVE COMBINA.CR/VANA T/ACES  
13/16  
**REF B=8.7 REF C=9.16**



**7/8"**



**MHT-8458 REF A 6.35**  
PZA |LLAVE COMBINAD CR/VANA T/ACESA  
7/8  
**REF B=9.67 REF C=10.17**



**15/16"**



**MHT-8459 REF A 8.69**  
PZA |LLAVE COMBINA.CR/VANA T/ACES  
15/16  
**REF B=13.22 REF C=13.92**



**1"**



**MHT-8460 REF A 9.67**  
PZA |LLAVE COMBINAD CR/VANA T/ACESA  
1"  
**REF B=14.72 REF C=15.5**



**1.1/8"**

**UTUSTOOLS**

**MHT-8461 REF A 15.99**  
PZA | LLAVE COMBINA.CR/VANA T/ACES  
1.1/8  
**REF B=24.34 REF C=25.62**



**1.1/4"**

**UTUSTOOLS**

**MHT-8462 REF A 6.59**  
PZA | LLAVE COMBINA.CR/VANA T/ACES  
1.1/4  
**REF B=10.02 REF C=10.55**



**1.1/16"**

**UTUSTOOLS**

**MHT-8464 REF A 13.33**  
PZA | LLAVE COMBINA.CR/VAN T/ACES  
1.1/16  
**REF B=20.29 REF C=21.36**



**1.3/16"**

**UTUSTOOLS**

**MHT-8465 REF A 14.88**  
PZA | LLAVE COMBINA.CR/VAN T/ACES  
1.3/16  
**REF B=22.64 REF C=23.83**



**23mm**

**UDUKE**

**MHT-8473 REF A 3.24**  
PZA | LLAVE COMB.CR/VANAD T/ACESA  
23M UDE  
**REF B=4.93 REF C=5.19**



**6mm**

**UTUSTOOLS**

**MHT-8474 REF A 0.7**  
PZA | LLAVE COMBINA.CR/VANAD T/ACESA  
6MM  
**REF B=1.07 REF C=1.12**

**UDUKE**



**7mm**

**MHT-8475 REF A 0.78**  
PZA | LLAVE COMB.CR/VANAD T/ACESA  
7MM UDE  
**REF B=1.19 REF C=1.26**

**UDUKE**



**8mm**

**MHT-8476 REF A 0.73**  
PZA | LLAVE COMB.CR/VANAD T/ACESA  
8MM UDE  
**REF B=1.12 REF C=1.18**

**UDUKE**



**9mm**

**MHT-8477 REF A 0.75**  
PZA | LLAVE COMB.CR/VANAD T/ACES.9M  
UDEKE  
**REF B=1.14 REF C=1.2**

**11mm**



**UDUKE**

**MHT-8479 REF A 0.77**  
PZA | LLAVE COMB.CR/VANAD T/ACESA  
11M UDE  
**REF B=1.17 REF C=1.23**

**12mm**



**UDUKE**

**MHT-8480 REF A 0.87**  
PZA | LLAVE COMB.CR/VANAD T/ACESA  
12M UDE  
**REF B=1.32 REF C=1.39**

**13mm**



**UDUKE**

**MHT-8481 REF A 0.95**  
PZA | LLAVE COMB.CR/VANAD T/ACESA  
13M UDE  
**REF B=1.45 REF C=1.52**

**14mm**



**UDUKE**

**MHT-8482 REF A 1.14**  
PZA | LLAVE COMB.CR/VANAD T/ACESA  
14M UDEK  
**REF B=1.73 REF C=1.82**

**15mm**



**UDUKE**

**MHT-8483 REF A 1.22**  
PZA | LLAVE COMB.CR/VANAD T/ACESA  
15M UDE  
**REF B=1.86 REF C=1.95**

**16mm**



**UDUKE**

**MHT-8484 REF A 1.27**  
PZA | LLAVE COMB.CR/VANAD T/ACESA  
16M UDE  
**REF B=1.93 REF C=2.03**

**17mm**



**UDUKE**

**MHT-8485 REF A 1.42**  
PZA | LLAVE COMB.CR/VANAD T/ACESA  
17M UDE  
**REF B=2.16 REF C=2.27**

**18mm**



**UDUKE**

**MHT-8486 REF A 1.6**  
PZA | LLAVE COMB.CR/VANAD T/ACES.18M  
UDEK  
**REF B=2.44 REF C=2.57**

**19mm**



**UDUKE**

**MHT-8487 REF A 1.77**  
PZA | LLAVE COMB.CR/VANAD T/ACESA  
19M UDE  
**REF B=2.69 REF C=2.84**

**20mm**



**UTUSTOOLS**

MHT-8488 REF A 5.04  
PZA | LLAVE COMBINA.CR/VANAD T/ACESA  
20M  
REF B=7.67 REF C=8.07

**21mm**



**UTUSTOOLS**

MHT-8489 REF A 5.95  
PZA | LLAVE COMBINA.CR/VANAD T/ACESA  
21M  
REF B=9.06 REF C=9.53

**22mm**



**UTUSTOOLS**

MHT-8490 REF A 2.74  
PZA | LLAVE COMBINA.CR/VANAD T/ACESA  
22M  
REF B=4.17 REF C=4.39

**24mm**



**UDUKE**

MHT-8491 REF A 3.54  
PZA | LLAVE COMB.CR/VANAD T/ACESA  
24M UDE  
REF B=5.39 REF C=5.67

**25mm**



**UTUSTOOLS**

MHT-8492 REF A 5.47  
PZA | LLAVE COMBINA.CR/VANAD T/ACESA  
25M  
REF B=8.32 REF C=8.76

**26mm**



**UTUSTOOLS**

MHT-8493 REF A 10.07  
PZA | LLAVE COMBINA.CR/VANAD T/ACESA  
26M  
REF B=15.33 REF C=16.13

**28mm**



**UTUSTOOLS**

MHT-8494 REF A 13.16  
PZA | LLAVE COMBINA.CR/VANAD T/ACESA  
28M  
REF B=20.02 REF C=21.08

**32mm**



**UTUSTOOLS**

MHT-8495 REF A 17.79  
PZA | LLAVE COMBINA.CR/VANAD T/ACESA  
32M  
REF B=27.07 REF C=28.49

**10 PIEZAS  
TIPO A3**

1.5MM - 2MM - 2.5MM - 3MM - 5MM  
4MM - 5MM - 6MM - 8MM - 10MM | TAMAÑOS  
SIZES



**ZASC**

MHT-8497 REF A 1  
SET | LLAV.ALLEN HEX.MILIME.1.5-10M 10P  
ZA  
REF B=1.53 REF C=1.61



**T10 AL T50**



**MHT-8508 REF A 4.23**  
 BLT | LLAV TORX T/LJG 9Pz C/H T-10 AL 50  
 REF B=6.43 REF C=6.77



**T9 - T40**



**MHT-8511 REF A 3.21**  
 SET | LLAVE TORX ALLEN 8Pz T-9aT40  
 DT20152  
 REF B=4.88 REF C=5.14



**1/2" 13mm**



**MHT-8560 REF A 3.31**  
 PZA | MANDRI.TALAD.AJUST.RAP.S/LLAV  
 1/2-13  
 REF B=5.03 REF C=5.3



**1/2"x20**



**MHT-8561 REF A 3.61**  
 PZA | MANDRIL P/TALADRO C/LL 1/2X20  
 DT/Q7  
 REF B=5.49 REF C=5.78

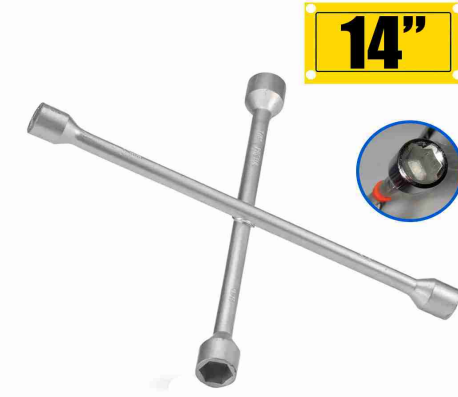

**14"**



**MHT-8562 REF A 8.68**  
 PZA | LLAVE CRUZ CROMADA 14 CW14  
 REF B=13.22 REF C=13.91



**20"**



**MHT-8563 REF A 17.8**  
 PZA | LLAVE DE CRUZ P/VEHICULOS 20"  
 REF B=27.09 REF C=28.52



**25"**



**MHT-8565 REF A 74.65**  
 PZA | LLAVE DE CRUZ P/CAMION 25"  
 REF B=113.61 REF C=119.58



**12"**

**MHT-8570 REF A 1.34**  
 PZA | MANGUERA P/ENGRASADORA  
 12"310BAR IM  
 REF B=2.03 REF C=2.14



**22"**



**MHT-8591 REF A 4.99**  
 PZA | MACHET.ROZAD.NAT.3CAN.  
 +LIMA.22"GAVIL  
 REF B=7.59 REF C=7.99

10 a 120L



MHT-8593 REF A 0.89  
PZA |MEDID.DE AIRE P/CARRO 10A100PSI  
Q7  
REF B=1.35 REF C=1.42

100lbs



MHT-8594 REF A 2.17  
PZA |MEDIDOR PRESION AIRE CARR.100LB  
503  
REF B=3.3 REF C=3.48

0-100Psi



MHT-8595 REF A 2.4  
PZA |MEDIDOR DE AIRE P/CARRO 0A100PS  
211  
REF B=3.66 REF C=3.85

160LB



MHT-8596 REF A 5.69  
PZA |MEDIDOR AIRE CAUCHO CAMION  
160LB Q7  
REF B=8.67 REF C=9.12

160LBS



MHT-8598 REF A 4.07  
PZA |MEDIDOR AIRE CAUCHO CAMION  
160LB 03  
REF B=6.2 REF C=6.53



MHT-8617 REF A 0.51  
PZA |MANGO PLASTICO P/CABO DE PALA  
REF B=0.78 REF C=0.82

180°



MHT-8621 REF A 2.39  
PZA |MIRILLA CROMADA DE 180grado  
REF B=3.63 REF C=3.82

180°



MHT-8622 REF A 2.3  
PZA |MIRILLA LATONADA DE 180grado  
REF B=3.49 REF C=3.68

0-25mm  
0.01mm



MHT-8628 REF A 8.23  
PZA |MICROMETRO 0-25MM/0.01MM  
DIESEL 182  
REF B=9.08 REF C=8.61



**16mm  
x 2**



**MHT-8642 REF A 14.94**  
JGO | MACHOS MA 16mmX2.00 JGO 3PZA  
VINK  
**REF B=22.73 REF C=23.93**



**18mm  
x 2.50**



**MHT-8643 REF A 19.7**  
JGO | MACHOS MA 18mmX2.50 JGO 3PZA  
VINK  
**REF B=29.98 REF C=31.56**



**9mm  
x 1**



**MHT-8652 REF A 4.75**  
JGO | MACHOS MB 9mm X1.00 JGO 3PZA  
VINK  
**REF B=7.23 REF C=7.61**



**11mm  
x 1**



**MHT-8654 REF A 6.82**  
JGO | MACHOS MB 11mmX1.00 JGO 3PZA  
VINK  
**REF B=10.38 REF C=10.93**



**3/16"  
NC24**



**MHT-8660 REF A 2.78**  
JGO | MACHOS.NC R/GRU.3/16-24 JG.3P  
31624  
**REF B=4.24 REF C=4.46**



**1/4" NC  
3PCS**



**MHT-8662 REF A 3.83**  
JGO | MACHOS N.C R/GRUE.1/4-20 JG.3P  
1420  
**REF B=5.83 REF C=6.13**



**5/16"  
NC18**



**MHT-8664 REF A 4.18**  
JGO | MACHOS N.C R/GRUE.5/16X18 JG3  
51618  
**REF B=6.36 REF C=6.69**



**3/8"  
NC16**



**MHT-8666 REF A 4.35**  
JGO | MACHOS N.C R/GRUE.3/8-16 JG3  
03816  
**REF B=6.62 REF C=6.97**



**7/16"  
NC14**



**MHT-8668 REF A 4.52**  
JGO | MACHOS NC R/GRUE.7/16-14 JG 3  
71614  
**REF B=6.89 REF C=7.25**



**1/2" NC13**



**MHT-8670 REF A 3.06**  
JGO | MACHOS N.C R/GRUE.1/2X13 JG 3  
01213  
**REF B=4.65 REF C=4.9**

**9/16" NC12**



**MHT-8672 REF A 6.09**  
JGO | MACHOS N.C R/GRUE.9/16-12 JG3  
91612  
**REF B=9.27 REF C=9.76**

**5/8" NC11**



**MHT-8674 REF A 3.97**  
JGO | MACHOS N.C R/GRUE.5/8-11 JG 3P  
5811  
**REF B=6.05 REF C=6.37**

**3/4mm x 10"**



**MHT-8676 REF A 19.9**  
JGO | MACHOS N.C R/GRU.3/4x10 JG.3Pz  
VINKO  
**REF B=30.29 REF C=31.89**

**3/16" NF32**



**MHT-8682 REF A 2.61**  
JGO | MACHOS(N.F)R/FIN.3/16-32 JG 3  
31632  
**REF B=3.97 REF C=4.18**

**1/4" NF28**



**MHT-8684 REF A 3.83**  
JGO | MACHOS(N.F)R/FINA 1/4x28 JG 3  
01428  
**REF B=5.83 REF C=6.13**

**5/16" NF24**



**MHT-8686 REF A 4.18**  
JGO | MACHOS(N.F)R/FINA 5/16 JGO 3P  
51624  
**REF B=6.36 REF C=6.69**

**3/4" NF24**



**MHT-8688 REF A 4.18**  
JGO | MACHOS (N.F)R/FIN.3/8-24 JG 3  
03824  
**REF B=6.36 REF C=6.69**

**7/16" NF20**



**MHT-8690 REF A 4.52**  
JGO | MACHOS(N.F)R/FIN.7/16-20 JG 3  
71620  
**REF B=6.89 REF C=7.25**



**1/2" NF20**



**MHT-8692 REF A 5.22**  
JGO | MACHOS(N.F)R/FINA 1/2x20 JG 3P 1220  
**REF B=7.94 REF C=8.36**



**9/16" NF18**



**MHT-8694 REF A 6.09**  
JGO | MACHOS.N.F)R/FIN.9/16-18 JG.3P 91618  
**REF B=9.27 REF C=9.76**



**5/8" NF18**



**MHT-8696 REF A 15.26**  
JGO | MACHOS(N.F)R/FINA 5/8x18 JG.3P 5818  
**REF B=23.22 REF C=24.44**



**3/4-16**



**MHT-8698 REF A 24.56**  
JGO | MACHOS(N.F)R/FIN.3/4-16 JG.3Pz VNK  
**REF B=37.39 REF C=39.35**



**1/4" N.P.T**



**MHT-8704 REF A 1.8**  
PZA | MACHOS (N.P.T) 1/4" DIESEL NPT014  
**REF B=2.74 REF C=2.88**



**3/8" N.P.T**



**MHT-8706 REF A 2.64**  
PZA | MACHOS (N.P.T) 3/8" DIESEL NPT038  
**REF B=4.02 REF C=4.23**



**1/2" N.P.T**



**MHT-8708 REF A 2.76**  
PZA | MACHOS (N.P.T) 1/2" DIESEL NPT012  
**REF B=4.2 REF C=4.42**

**86-1**



**MHT-8819 REF A 0.54**  
PZA | NIVEL HILO PLAST 86-1 IMP SUELTOS  
**REF B=0.83 REF C=0.87**



**MHT-8865 REF A 1.35**  
PZA | PICO PARA ENGRASADORA MANUAL  
**REF B=2.06 REF C=2.17**



**40W**

**DIESEL TOOLS**

MHT-8914 REF A 1.97  
PZA | PISTOLA SOLDAR TIPO CAUTIN 40W DT57

REF B=3 REF C=3.16



**100W**

**DIESEL TOOLS**

MHT-8916 REF A 8.87  
PZA | PISTOLA PARA SOLDAR 100W DT-1 802

REF B=13.5 REF C=14.21



**100W**

**Best Value**  
USA PRODUCTOS DE CALIDAD

MHT-8918 REF A 19.87  
PZA | PISTOLA PARA SOLDAR BESTVALUE 100W

REF B=30.25 REF C=31.84



**24D**

MHT-8944 REF A 2.76  
PZA | RASTRILLO PALMA PLAST.24DT C/ CAB.IMP

REF B=4.19 REF C=4.41



**1000W 110V**

MHT-8964 REF A 17.68  
PZA | RESISTE.CALENTADOR 1000W 110V ITAL

REF B=26.92 REF C=28.33



**1500W 110V**

MHT-8966 REF A 18.07  
PZA | RESISTEN.CALENTADO.1500W 110V ITAL

REF B=27.5 REF C=28.94



**7 PCS**

**DIESEL TOOLS**

MHT-8995 REF A 33.5  
JGO | KIT P/LATONERO DE 7 PZAS.DS-RH007

REF B=50.99 REF C=53.67



**1/8-1/4" 10PCS**

**MAXI TOOLS**

MHT-8996 REF A 2.29  
KIT | KIT PIEDR ABRA.P/TALD.1/8-1/4 10PZ

REF B=3.48 REF C=3.67



**1/4" 5PCS**

**DIESEL TOOLS**

MHT-8997 REF A 1.4  
KIT | KIT PIEDRA ABRAS.P/TALADRO 1/4 5pza

REF B=2.14 REF C=2.25

150 PIEZAS



MHT-9000 REF A 2.32  
KIT | KIT DE CUPILLAS 150PZA SURTIDAS

REF B=3.53 REF C=3.72

300Pcs



MHT-9001 REF A 5.01  
KIT | KIT DE RETENES 300PZA SURT.DT-KD300

REF B=7.63 REF C=8.03

200PCS



MHT-9002 REF A 4.16  
KIT | KIT DE RESORTE 200PZ SURTIDAS DS200

REF B=6.34 REF C=6.67

200PCS



MHT-9003 REF A 3.57  
KIT | KIT RESORTE SURTIDO 200PCS SEA M5

REF B=5.44 REF C=5.73

222 PIEZAS



MHT-9004 REF A 4.89  
KIT | KIT DE ORING 222 PZA SURTIDAS DIESE

REF B=7.45 REF C=7.84

280PCS



MHT-9005 REF A 12.22  
KIT | KIT ARANDELA COBRE 280 PZA DT-280

REF B=18.61 REF C=19.58

110 PCS



MHT-9006 REF A 10.25  
KIT | KIT D/GRASERA 110 PIEZAS/SURTIDA DT

REF B=15.61 REF C=16.43

110 PCS



MHT-9007 REF A 7.72  
KIT | KIT D/GRASERA 110 PIEZAS/SURTID.M04

REF B=11.74 REF C=12.36



MHT-9009 REF A 1.77  
KIT | KIT PIED/CEP/ESC.DREME P/PULIR 12P D

REF B=2.69 REF C=2.84



**8PCS**



**MHT-9010 REF A 5.28**  
KIT | KIT TERMINAL DE BATERIA 8PZ DS-J001  
**REF B=8.04 REF C=8.46**



**3-12mm 800pcs**



**MHT-9011 REF A 4.23**  
KIT | KIT ARANDELAS PRESION 3-12M 800Pza  
**REF B=6.43 REF C=6.77**



**MHT-9012 REF A 0.99**  
KIT | KIT TERMINAL D/BATERIA 2PZ DS-BT002  
**REF B=1.5 REF C=1.58**



**105PCS**



**MHT-9013 REF A 4.11**  
KIT | KIT TUERCAS MARIPOSA 150Pza SEA.M11  
**REF B=6.25 REF C=6.58**



**150PCS/SET WING NUT ASSORTMENT**



**MHT-9014 REF A 5.9**  
KIT | KIT TUERCAS MARIPOSA 150Pza WN150  
**REF B=8.97 REF C=9.44**



**146PCS**



**MHT-9015 REF A 4.53**  
KIT | KIT TUERCAS SEGURID.SURT.146PZ 6058  
**REF B=6.89 REF C=7.25**



**127PCS**



**MHT-9017 REF A 1.97**  
KIT | KIT TERMOENCOGIBLE SURT.Q7-HS127PZA  
**REF B=3 REF C=3.16**



**127PCS**



**MHT-9018 REF A 1.97**  
KIT | KIT TERMOENCOGIBLE SURTIDOS 127 PZA  
**REF B=3 REF C=3.16**



**127pcs**



**MHT-9019 REF A 1.57**  
KIT | KIT TERMOENCOGIB.SURTID.127P.VOL TSHT  
**REF B=2.39 REF C=2.51**



**164pcs**



**MHT-9022 REF A 2.34**  
KIT | KIT TERMOENCOGIBLE COLOR  
SURT.164PZ  
REF B=3.56 REF C=3.75

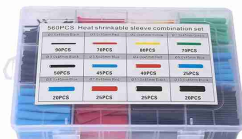

**400PCS**



**MHT-9024 REF A 3.71**  
KIT | KIT TERMOENCOG.COLOR  
SURT.400PZ M16  
REF B=5.64 REF C=5.94



**110v-60w**



**MHT-9030 REF A 6.73**  
PZA |KIT 8pz D/SOLDADURA C/CAUTIN  
60W SEA  
REF B=10.24 REF C=10.78



**1/4"**



**MHT-9050 REF A 2.17**  
PZA |KIT INFLA CAUCH.P/MANG-AIRE  
1/4"614  
REF B=3.3 REF C=3.48



**151 PCS**



**MHT-9053 REF A 3.21**  
PZA |KIT ARMELLA ABIER-CERR. 151PZA  
M06  
REF B=4.88 REF C=5.14



**345PCS**



**MHT-9058 REF A 3.21**  
KIT | KIT CUPILLAS 345PZA SURTIDAS  
SEA.M9  
REF B=4.88 REF C=5.14



**555Pcs**



**MHT-9060 REF A 6.39**  
KIT | KIT DE CUPILLAS 555PZA SURTIDAS Q7  
REF B=9.72 REF C=10.23



**270PCS**



**MHT-9063 REF A 5.02**  
KIT | KIT ORING 270PZ.VERDE SURT.Q7/  
DS270  
REF B=7.63 REF C=8.03



**387 Pcs**



**MHT-9065 REF A 6.9**  
KIT | KIT ORING 387 PZA SURTIDAS  
DS.DT387  
REF B=10.5 REF C=11.05



**270Pcs**

**MHT-9070 REF A 5.51**  
**KIT | KIT CONECTOR RAPIDO CABLE**  
**120PCS Q7**  
**REF B=8.39 REF C=8.83**



**28Pzas**

**MHT-9075 REF A 3.84**  
**KIT | KIT PINZAS ELECTRICAS SURTID.28PZA**  
**REF B=5.85 REF C=6.15**



**60pcs**

**MHT-9077 REF A 4.71**  
**KIT | KIT PINZAS**  
**ELECTR.SURT.60PZ.SEA.M10**  
**REF B=7.17 REF C=7.54**



**MHT-9135 REF A 10.51**  
**JGO | SALPICADOR PEINES DE REPUESTOS**  
**REF B=16 REF C=16.84**



**1/2-3/4-1"**

**MHT-9212 REF A 4.58**  
**JGO | TARRAJA MANU.PLAS.1/2-3/4-1"MAP/WQ**  
**REF B=6.96 REF C=7.33**



**1/2-3/4-1"**

**MHT-9216 REF A 6.37**  
**PZA | TARRJ.MAN.P/T PVC1/2-3/4-1"M/NUEVO**  
**REF B=9.69 REF C=10.2**



**3/4x20MTS**

**MHT-9235 REF A 16.02**  
**PZA | TEIPE ELECT.SUPER 3M N33**  
**3/4X20MTS**  
**REF B=24.39 REF C=25.67**



**3/4**

**MHT-9236 REF A 0.99**  
**RLL | TEIPE ELE.COBRAS U.S.A 3/4X60FT GRD**  
**REF B=1.51 REF C=1.59**



**3/4"x18M**

**MHT-9242 REF A 1.81**  
**RLL | TEIPE ELE.COBRAS 3/4 X 60FT**  
**AMARILLO**  
**REF B=2.75 REF C=2.9**



**3/4"x18M**



**MHT-9243 REF A 1.81**  
RLL | TEIPE ELE.COBRÁ 3/4 X 60FT BLANCO

**REF B=2.75 REF C=2.9**



**3/4"x18M**



**MHT-9244 REF A 1.81**  
RLL | TEIPE ELE.COBRÁ 3/4 X 60FT AZUL

**REF B=2.75 REF C=2.9**



**3/4"x18M**



**MHT-9246 REF A 1.88**  
RLL | TEIPE ELE.COBRÁ 3/4 X 60FT ROJO

**REF B=2.86 REF C=3.01**



**1/2"x0.075mm  
x10MTS**



**MHT-9264 REF A 0.14**  
PZA | TEFLON 1/2 X 0.075MM X 10MTS PTFE

**REF B=0.21 REF C=0.22**



**1/2  
x7MTS**



**MHT-9266 REF A 0.22**  
PZA | TEFLON 1/2 X 7 MTS.

**REF B=0.34 REF C=0.35**



**3/4" x 15mts x  
0.2mm**



**MHT-9268 REF A 0.4**  
PZA | TEFLON PROFESIONAL 3/4X15MT  
X0.20M

**REF B=0.61 REF C=0.64**



**19mm x  
0.1mm x 20M**



**MHT-9269 REF A 0.52**  
PZA | TEFLON PROF.3/4 X0.1M X 20MT  
AQUA-Q

**REF B=0.79 REF C=0.83**



**3/4"  
x15MTS**



**MHT-9270 REF A 0.52**  
PZA | TEFLON PROFES.3/4X0.2MX15 MTS  
WOLF

**REF B=0.79 REF C=0.83**



**1000/1500w  
110V**

**MHT-9287 REF A 6.57**  
PZA | TERMOSTATO P/CALEN.1000/1500w  
110V

**REF B=10 REF C=10.53**





MHT-9368 REF A 30.16  
PZA | TORQUIMETRO DE 1/2" 150 LB-FT Q7

REF B=45.9 REF C=48.32



**Voltage**  
electronics part

MHT-9430 REF A 13.39  
RLL | TERMOENCOGIBLE 10MM X 100 MTS VOLTG

REF B=20.38 REF C=21.46



**Voltage**  
electronics part

MHT-9435 REF A 13.59  
RLL | TERMOENCOGIBLE 12MM X 100 MTS VOLTG

REF B=20.69 REF C=21.78



**DIESEL TOOLS**

MRA-0058 REF A 8.55  
SET | ALFOMBRA P/CARRO GOMA 3 PCS DIESEL

REF B=13.01 REF C=13.7



**Wolfgang**

MRA-0065 REF A 8.38  
SET | ALFOMBRA P/CARRO GOMA 4 PCS CM-4P

REF B=12.76 REF C=13.43



MRA-0100 REF A 14.26  
KIT | AMOLADOR CILINDRO 3GARRAS P/ MOTOR DI

REF B=21.71 REF C=22.85



MRA-0900 REF A 5.21  
PZA | CABLE AUXILIAR BATERIA 2MTS 1000AMP

REF B=7.93 REF C=8.35



**TEG**

MRA-0910 REF A 9.99  
SET | CABL.AUXIL.BATERIA 3.65M 6AWG 350A VT

REF B=15.2 REF C=16



MRA-0980 REF A 24.05  
PZA | CARRO MECANIC.102X48X5CM 150KG C/R

REF B=36.6 REF C=38.52

**C/18-16**



**MRA-1010** REF A 4.08  
PQT |CAPUCHON NARANJA C/18-16 P/  
CABLE

REF B=6.21 REF C=6.53

**C/14-10**



**MRA-1020** REF A 6.8  
PQT |CAPUCHON AMARILLO C/14-10 P/  
CABLE

REF B=10.34 REF C=10.89

**270mm**



**DIESEL TOOLS**

**MRA-1300** REF A 13.53  
PAR |COMPRESOR RESORTE P/ESPIRAL  
270MM DS

REF B=20.59 REF C=21.67



**12V  
150PSI-85L**

HEAVY DUTY AIR COMPRESSOR  
Voltage DC 12V-13.5V  
Max Amperage 23 Amp  
Max pressure 150 PSI  
Filter Rate 85L/Min  
CAUTION: The Unit May Get Hot When  
Operated For Long Periods Of Time.  
WATER RESISTANT

**MRA-1350** REF A 57.01  
PZA |COMPRES.AIR.12V 150PSI 85L/MIN  
YUNG

REF B=86.78 REF C=91.34



**DIESEL TOOLS**



**MRA-2250** REF A 10.19  
KIT | EXTRACTOR D/RESORTE DE VALVULA  
DIES

REF B=15.5 REF C=16.32

**15Amp**

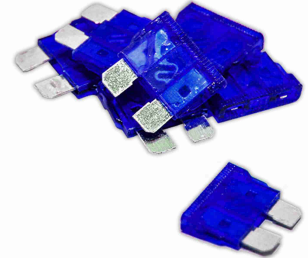

**MRA-2805** REF A 6.04  
CJA | FUSIBLE T/MUEL.AT15AMP AZUL  
C/100p

REF B=9.19 REF C=9.68

**20Amp**



**MRA-2810** REF A 6.04  
CJA | FUSIBLE T/MUEL.AT 20AMP AMAR  
C/100p

REF B=9.19 REF C=9.68

**25Amp**



**MRA-2815** REF A 6.04  
CJA | FUSIBLE T/MUEL.AT25AMP TRAS  
C/100p

REF B=9.19 REF C=9.68

**30Amp**



**MRA-2820** REF A 6.04  
CJA | FUSIBLE T/MUEL.AT30AMP VERD  
C/100p

REF B=9.19 REF C=9.68

**40 Amp**



**MRA-2830 REF A 6.04**  
CJA | FUSIBLE T/MUELA AT 40AMP MORA  
C/100p  
REF B=9.19 REF C=9.68



**DIESEL TOOLS**

**MRA-4200 REF A 47.19**  
JGO | KIT SEPARADOR REMOVEDOR MUNON  
J010  
REF B=71.83 REF C=75.61



**DIESEL TOOLS**

**MRA-4210 REF A 32.45**  
JGO | KIT HERRAM.SINCRONIZACION  
MOTOR 302  
REF B=49.38 REF C=51.98



**DIESEL TOOLS**

**MRA-4212 REF A 36.67**  
KIT | KIT SINCRONIZAC.TIEMP.FORD-MAZD  
T16  
REF B=55.82 REF C=58.75



**DIESEL TOOLS**

**MRA-4215 REF A 18.09**  
JGO | KIT HERRAM.AJUST.TIEMPO  
AUTOMOTR.16  
REF B=27.54 REF C=28.99



**DIESEL TOOLS**

**MRA-4220 REF A 53.09**  
JGO | KIT EXTRACTOR MARTILLO D/REBOTE  
016  
REF B=80.8 REF C=85.05

**3/8"**



**DIESEL TOOLS**

**MRA-4223 REF A 39.73**  
JGO | KIT COPA CAMB.FILT.ACEI.RAC.3/8  
001  
REF B=60.47 REF C=63.65

**3/8"**



**DIESEL TOOLS**

**MRA-4225 REF A 28.57**  
JGO | KIT COPA CAMB.FILT.ACEI.RAC.3/8  
007  
REF B=43.49 REF C=45.78



**DIESEL TOOLS**

**MRA-4227 REF A 32.45**  
JGO | KIT COPA/CAMB.FIL.ACEI.15P C/LL  
015  
REF B=49.39 REF C=51.98

15PC ALUMINUM L1L FILTER CAP WRENCH SOCKET  
GENERAL TOOL SET

TYPE	SIZE(mm)	INCH	SET INCL. EQUIPMENT USE
15C	42	1 1/2	TOYOTA, NISSAN, FORD, DAIHATSU
15D	42	1 1/2	DAIHATSU, TOYOTA
15E	71	1 3/4	AUDI, ROVER, CHRYSLER
15F	71	1 3/4	TOYOTA, LEXUS
15G	79	1 1/2	NISSAN, FORD
15H	71	1 3/4	DAIKO, HONDA, VOLVO, ALFA, VAG
15I	84	1 3/8	BAWAG, SCHLIPPER
15J	88	1 3/8	NISSAN, TOYOTA
15K	92	1 3/8	ISUZU, NISSAN
15L	98	1 3/8	TOYOTA, ALFA ROMEO, FORD
15M	79	1 1/2	FIVE BRANCH, CHRYSLER
15N	79	1 1/2	TOYOTA, HONDA, NISSAN, CHRYSLER
15O	88	1 3/8	MAZDA, TOYOTA
15P	92	1 3/8	FREZZA, INC



**DIESEL TOOLS**

**MRA-4231 REF A 30.56**  
**JGO |KIT EXTRACT.RODAMIENTO INTERNO**  
 992

**REF B=46.51 REF C=48.96**



**DIESEL TOOLS**

**MRA-4232 REF A 19.36**  
**JGO |KIT EXTRAC.POLEA BOMBA**  
 DIRECCIO.795

**REF B=29.46 REF C=31.01**



**DIESEL TOOLS**

**MRA-4237 REF A 23.55**  
**JGO |KIT MEDIDOR COMPRESION CILINDRO**  
 U21

**REF B=35.84 REF C=37.72**



**DIESEL TOOLS**

**MRA-4242 REF A 91.68**  
**JGO |KIT EXTRA/MONTA BUJE MESET-**  
 RUEDA023

**REF B=139.54 REF C=146.88**



**DIESEL TOOLS**

**MRA-4245 REF A 14.73**  
**JGO |K.PROBAD.COMPRESION MOTOR**  
 GASOL.016

**REF B=22.42 REF C=23.6**



**DIESEL TOOLS**

**MRA-4247 REF A 24.63**  
**JGO |KIT PROB.PRESION**  
 BOMB.ACEIT.MOTOR06

**REF B=37.49 REF C=39.46**



**DIESEL TOOLS**

**MRA-4248 REF A 71.31**  
**JGO |KIT**  
 MEDID.PRES.INYECCI.BOMB.GASOL43

**REF B=108.53 REF C=114.24**



**DIESEL TOOLS**

**MRA-4249 REF A 23.43**  
**JGO |K.PROB.COMPRESION MOTOR**  
 GASOL.B7007

**REF B=35.66 REF C=37.54**



**DIESEL TOOLS**

**MRA-4252 REF A 50.94**  
**JGO |KIT DE CAMBIO DE GOMA VALVULA**  
 15303

**REF B=77.52 REF C=81.6**



**MRA-4257** REF A 48.18  
KIT | KIT EXTRACTOR D/GUIA D/VALVULAS  
061  
REF B=73.33 REF C=77.18



**MRA-4260** REF A 49.16  
KIT | K.EXTRA.INT/EXT.C/MART.DEZLIZ.3G  
05  
REF B=74.83 REF C=78.76



**MRA-4270** REF A 32.45  
SET | KIT 7pz PICO ASCESOR.P/  
PIST.ENGRASE  
REF B=49.39 REF C=51.98



**MRA-4275** REF A 28.51  
KIT | KIT COMPRES.UNIV.D/  
RESORT.VALVU4025  
REF B=43.39 REF C=45.67



**MRA-4280** REF A 27.5  
KIT | KIT PULIDOR CILINDR.FRENO+MOTOR  
86Z  
REF B=41.86 REF C=44.06



**MRA-4283** REF A 23.32  
KIT | KIT PULGADOR FRENO-VACIO C/  
BOMBA 22  
REF B=35.49 REF C=37.35



**MRA-4290** REF A 39.08  
KIT | K.INSTALAC.ANILLO-PISTON MOTOR  
P011  
REF B=59.48 REF C=62.6



**MRA-4295** REF A 15.73  
KIT | K.INSTALAC.EXTRA.SELLOS  
VALVUL.011  
REF B=23.94 REF C=25.2



**MRA-4300** REF A 47.19  
KIT | K.INSTAL.REMOVED.SELLO MANIVELA  
R24  
REF B=71.83 REF C=75.61



**DIESEL TOOLS**

**MRA-4310 REF A 66.13**  
 KIT | K.PROB.MEDID.FUGAS P/RADIADORES  
 014  
**REF B=100.65 REF C=105.94**



**DIESEL TOOLS**

**MRA-4400 REF A 56.11**  
 KIT | K.EMERG.AUTO  
 AIRE+ENERGIA+LINT+USB  
**REF B=85.4 REF C=89.89**



**DIESEL TOOLS**

**MRA-4980 REF A 7.43**  
 PZA | LLAV.RUED.TELESOP.1/2"X17-19-21-  
 23M  
**REF B=11.31 REF C=11.91**



**DIESEL TOOLS**

**MRA-4995 REF A 3.51**  
 PZA | LLAV.SACAR FIL.ACEIT.3GAR.53-84M  
 03  
**REF B=5.34 REF C=5.62**



**DIESEL TOOLS**

**MRA-5000 REF A 6.41**  
 PZA | LLAV.SACAR FILT.ACEITE  
 3GAR.65-130M  
**REF B=9.76 REF C=10.27**



**DIESEL TOOLS**

**MRA-5450 REF A 52.1**  
 PZA | MEDIDOR PRESION D/CILINDRO P/  
 CAMION  
**REF B=79.3 REF C=83.47**



**DIESEL TOOLS**

**MRA-5460 REF A 18.04**  
 KIT | KIT MEDID.PRES-  
 BOMB.GASL.INYEC.D113  
**REF B=27.45 REF C=28.89**



**DIESEL TOOLS**

**MRA-5467 REF A 15.28**  
 KIT | KIT MEDIDOR PRES.BOMBA GASOLINA  
 TU1  
**REF B=23.26 REF C=24.48**



**DIESEL TOOLS**

**MRA-5470 REF A 52.97**  
 KIT | K:PUNTA+DADO.COMB.POLEA  
 ALTERNAD.024  
**REF B=80.62 REF C=84.86**



**DIESEL TOOLS**

**MRA-5520 REF A 16.27**  
PZA | MORDAZA PARA LATONERIA DS-SM125  
REF B=24.76 REF C=26.06

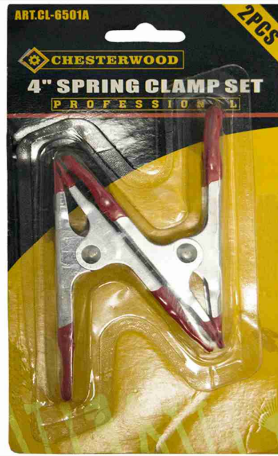

**MRA-5842 REF A 2.82**  
BLT | PINZA METALICA DE RESORTE 4'2pza  
REF B=4.3 REF C=4.52



**MRA-5844 REF A 4.98**  
BLT | PINZA METALICA DE RESORTE 6'2pza  
REF B=7.58 REF C=7.98



**30AMP**

**MRA-5850 REF A 0.78**  
PAR | PINZA P/CABLE 30 AMP ROJO/NEGRA PAR  
REF B=1.19 REF C=1.26



**190mm**

**MRA-5935 REF A 2.34**  
PZA | PUENTE PARA BATERIA 190MM 7.6" 019  
REF B=3.56 REF C=3.74



**230mm**

**MRA-5937 REF A 2.46**  
PZA | PUENTE PARA BATERIA 230MM 9.2" 023  
REF B=3.74 REF C=3.94



**270mm**

**MRA-5940 REF A 2.71**  
PZA | PUENTE PARA BATERIA 270MM 10.8" 027  
REF B=4.12 REF C=4.34

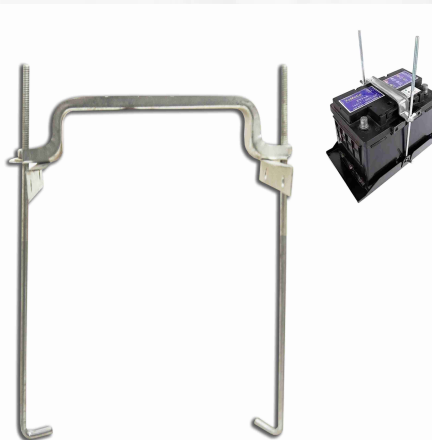

**MRA-5950 REF A 4.37**  
PZA | PUENTE PARA BATERIA GRANDE  
REF B=6.64 REF C=6.99



**6 Y 12 VOLTIOS**

**MRA-6000 REF A 1.87**  
PZA | PROBADOR DE 6 Y 12 VOLTIOS IMP  
REF B=2.85 REF C=3



**TESTER PARA CIRCUITO CERRADO O ABIERTO**



**DIESEL TOOLS**

**MRA-6005 REF A 1.67**  
PZA |PROBAD.DE CONTINUIDAD D/  
BATERIA.851  
REF B=2.54 REF C=2.68



**6-24v**



**DIESEL TOOLS**

**MRA-6007 REF A 8.42**  
PZA |PROB.6-12-24V HD.CABL/  
ESPIR+LED.030  
REF B=12.81 REF C=13.48



**6 y 12V**



**DIESEL TOOLS**

**MRA-6010 REF A 19.66**  
PZA |PROBADOR D/CARGA BATERIA 6 Y  
12V DIE  
REF B=29.92 REF C=31.49



**DIESEL TOOLS**

**MRA-6060 REF A 31.06**  
PZA |PROBAD.CHISPA BUJIA  
ENCEND.VEH.028  
REF B=47.28 REF C=49.76



**60cm**



**DIESEL TOOLS**

**MRA-6200 REF A 0.99**  
PZA |RECOJEDOR MAGNETIC.FLEXIBL.60CM  
025  
REF B=1.5 REF C=1.58



**4 GARRAS 56"**



**DIESEL TOOLS**

**MRA-6205 REF A 0.96**  
PZA |RECOJEDOR FLEXIB.4 GARRAS DE  
56"016  
REF B=1.46 REF C=1.54



**31"**



**MRA-6210 REF A 2.47**  
PZA |RECOJEDOR C/PUNTA IMANTADA C/  
LUZ 31"  
REF B=3.76 REF C=3.95



**19mm**



**DIESEL TOOLS**

**MRA-6450 REF A 12.53**  
PZA |SEPARADOR DE ROTULA NEGRA  
19MM S126  
REF B=19.06 REF C=20.07



**19mm**



**DIESEL TOOLS**

**MRA-6455 REF A 12.53**  
PZA |SEPARADOR DE ROTULA GRIS 19MM  
JS125  
REF B=19.06 REF C=20.07



**2"**



**MRA-6700 REF A 1.05**  
PZA | TAPA TAMBOR METALICO 2"

**REF B=1.6 REF C=1.68**



**MRA-6890 REF A 8.3**  
KIT | TERMINAL P/BREAK.IND  
EXCEL.BRE-5890

**REF B=12.63 REF C=13.3**

**1/8" AWG  
20-16**



**MRA-7004 REF A 4.53**  
PQT | TERM.ANILL.S/AIS.1/8 AWG 20-16  
LAT.

**REF B=6.89 REF C=7.26**

**5/32" AWG  
22-18**



**MRA-7005 REF A 6.04**  
PQT | TERM.ANILL.S/AIS.5/32AWG 22-18  
LAT

**REF B=9.19 REF C=9.68**

**3/16" AWG  
18-14**



**MRA-7006 REF A 7.55**  
PQT | TERM.ANILL.S/AIS.3/16 AWG 18-14  
LAT

**REF B=11.49 REF C=12.1**

**1/4" AWG  
18-14**



**MRA-7012 REF A 13.59**  
PQT | TERM.ANILL.S/AIS.1/4 AWG 18-14 LAT

**REF B=20.68 REF C=21.77**

**5/16" AWG  
18-14**



**MRA-7016 REF A 15.1**  
PQT | TER.ANIL.S/AIS.5/16 AWG 18-14 L/EST

**REF B=22.98 REF C=24.19**

**3/8" AWG  
18-14**



**MRA-7018 REF A 8.73**  
PQT | TER.ANIL.S/AIS.3/8 AWG 18-14  
LATON

**REF B=13.28 REF C=13.98**

**187 AWG  
22-18**



**MRA-7040 REF A 2.87**  
PQT | TER.HEM/REC.S/AIS.187AW22-18L/ES  
100P

**REF B=4.37 REF C=4.6**

**205 AWG  
22-18**



**MRA-7042 REF A 4.5**  
PQT |TER.HEM/REC.S/AIS.205AW 22-18LAT  
100P  
**REF B=6.85 REF C=7.21**

**205 AWG  
22-18**

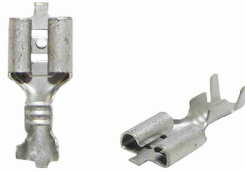

**MRA-7044 REF A 4.15**  
PQT |TER.HEM/REC.S/AIS.205AW 22-18L/ES  
100P  
**REF B=6.32 REF C=6.65**

**HEMBRA  
22/18**



**MRA-7806 REF A 6.19**  
PQT |TERMIN.ROJO 22/18 HEMBR AIS  
PV1257A  
**REF B=9.42 REF C=9.92**

**HEMBRA  
22/18**



**MRA-7812 REF A 6.42**  
PQT |TERMIN.ROJO 22/18 HEM.PL/M5  
V1255A  
**REF B=9.77 REF C=10.28**

**MACHO  
22/18 - M7**



**MRA-7818 REF A 3.47**  
PQT |TERMIN.ROJO 22/18 MAC.PL/M7  
V1257B  
**REF B=5.29 REF C=5.56**

**1/8"-M3  
22/18**



**MRA-7820 REF A 1.96**  
PQT |TERM.ROJ 22/18 ANILL.M3 1/8  
ARA125  
**REF B=2.99 REF C=3.14**

**5/32"-M4  
22/18**



**MRA-7821 REF A 1.96**  
PQT |TERM.ROJ 22/18 ANIL.M4 5/32  
RF1254  
**REF B=2.99 REF C=3.14**

**3/16"-M5  
22/18**



**MRA-7824 REF A 2.27**  
PQT |TERM.ROJ 22/18 ANILL.M5 3/16  
RF1255  
**REF B=3.45 REF C=3.63**

**1/4"-M6  
22/18**



**MRA-7827 REF A 3.47**  
PQT |TERM.ROJ 22/18 ANILLO.M6 1/4  
RF1256  
**REF B=5.29 REF C=5.56**

**1/8"-M3  
22/18**



**MRA-7830 REF A 1.96**  
PQT |TERM.ROJ 22/18 HORQ.M3 1/8  
YF1253  
**REF B=2.99 REF C=3.14**

**5/32"-M4  
22/18**



**MRA-7833 REF A 1.96**  
PQT |TERM.ROJ 22/18 HORQ.M4 5/32 YF  
1254  
**REF B=2.99 REF C=3.14**

**3/16"-M5  
22/18**



**MRA-7836 REF A 2.27**  
PQT |TERM.ROJ 22/18 HORQ.M5 3/16 YF  
1255  
**REF B=3.45 REF C=3.63**

**HEMBRA  
16/14**



**MRA-7845 REF A 6.19**  
PQT |TERM.AZUL 16/14 HEMB/  
AISLADO.PV27-A  
**REF B=9.42 REF C=9.92**

**HEMBRA-M5  
16/14-V25-A**



**MRA-7851 REF A 5.13**  
PQT |TERM.AZUL 16/14 HEMB/PLAN.M5  
V25-A  
**REF B=7.81 REF C=8.22**

**HEMBRA-M7  
16/14-V27-A**



**MRA-7854 REF A 4.64**  
PQT |TERM.AZUL 16/14 HEMB/PLAN.M7  
V27-A  
**REF B=7.06 REF C=7.43**

**MACHO-M7  
16/14 V27-B**



**MRA-7857 REF A 3.78**  
PQT |TERMI.AZUL 16/14 MACHO PLANO  
V27-B  
**REF B=5.75 REF C=6.05**

**5/32"-M4  
16/14 RF24**



**MRA-7860 REF A 2.27**  
PQT |TERM.AZUL 16/14 ANILLO.M4 5/32  
RF24  
**REF B=3.45 REF C=3.63**

**3/16"-M5  
16/14 RF25**



**MRA-7863 REF A 2.87**  
PQT |TERM.AZUL 16/14 ANILLO.M5 3/16  
RF25  
**REF B=4.37 REF C=4.6**

**1/4"-M6  
16/14 RF26**



**MRA-7866 REF A 3.62**  
PQT |TERM.AZUL 16/14 ANILLO.M6 1/4  
RF26  
**REF B=5.52 REF C=5.81**

**5/16"-M8  
16/14 RF28**



**MRA-7869 REF A 3.62**  
PQT |TERM.AZUL 16/14 ANILLO.M8 5/16  
RF28  
**REF B=5.52 REF C=5.81**

**1/8"-M3  
16/14 YF23S**



**MRA-7872 REF A 2.27**  
PQT |TERM.AZUL 16/14 HORQ.M3 1/8  
YF23S  
**REF B=3.45 REF C=3.63**

**5/32"-M4  
16/14 YF24**

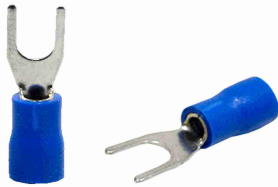

**MRA-7875 REF A 2.27**  
PQT |TERM.AZUL 16/14 HORQ.M4 5/32  
YF24  
**REF B=3.45 REF C=3.63**

**3/16"-M5  
16/14 YF25**



**MRA-7878 REF A 2.72**  
PQT |TERM.AZUL 16/14 HORQ.M5 3/16  
YF25  
**REF B=4.14 REF C=4.35**

**1/4"-M6  
16/14 YF26**

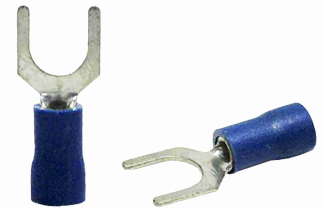

**MRA-7881 REF A 3.62**  
PQT |TERM.AZUL 16/14 HORQ.M6 1/4  
YF26  
**REF B=5.52 REF C=5.81**

**HEMBRA  
16/14 PV557A**



**MRA-7890 REF A 12.08**  
PQT |TERM.AMAR 16/14 HEMB/  
AISLAD.PV557-A  
**REF B=18.39 REF C=19.35**

**HEMBRA  
12/10 V557A**



**MRA-7891 REF A 13.59**  
PQT |TERM.AMAR 12/10 HEMB/REC 375  
V557-A  
**REF B=20.68 REF C=21.77**

**HEMBRA 250  
12/10 V557A**



**MRA-7892 REF A 6.16**  
PQT |TERM.AMAR 12/10 HEMB/PL 250  
V557-A  
**REF B=9.38 REF C=9.87**

**HEMB/MACHO  
12/10 280**



**MRA-7893 REF A 12.53**  
PQT |TERM.AMAR 12/10 HEMBRA/MACHO  
280  
**REF B=19.08 REF C=20.08**

**HEMB/REDON  
12/10 M7-280**

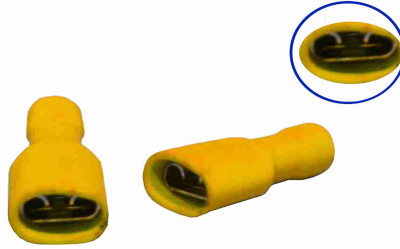

**MRA-7894 REF A 13.29**  
PQT |TERM.AMAR 12/10 HEMB/REDON M7  
195  
**REF B=20.22 REF C=21.29**

**MACHO REDO.  
12/10 195**



**MRA-7896 REF A 13.29**  
PQT |TERM.AMAR 12/10 MACHO/REDO 195  
**REF B=20.22 REF C=21.29**

**5/32" - M5  
12/10 AA156**



**MRA-7897 REF A 5.74**  
PQT |TERM.AMAR 12/10 ANIL.M5 5/32  
AA156  
**REF B=8.73 REF C=9.19**

**1/4" - M6  
12/10 RF556**



**MRA-7901 REF A 6.8**  
PQT |TERM.AMAR 12/10 ANIL.M6 1/4  
RF556  
**REF B=10.34 REF C=10.89**

**5/16" - M8  
12/10 RF558**



**MRA-7904 REF A 10.87**  
PQT |TERM.AMAR 12/10 ANIL.M8 5/16  
RF558  
**REF B=16.55 REF C=17.42**

**3/8" - M10  
12/10 RF5510**



**MRA-7907 REF A 11.02**  
PQT |TERM.AMAR 12/10 ANIL.M10 3/8  
RF5510  
**REF B=16.78 REF C=17.66**

**1/2" - M10  
12/10 AAA500**



**MRA-7908 REF A 17.82**  
PQT |TERM.AMAR 12/10 ANIL.M10 1/2  
AAA500  
**REF B=27.12 REF C=28.54**

**12/10"  
HORQ. M5 3/16"**



**MRA-7913 REF A 6.04**  
PQT |TERM.AMAR 12/10 HORQ.M5 3/16  
YF555  
**REF B=9.19 REF C=9.68**

12/10"  
HORQ. M6 1/4"



**MRA-7916 REF A 6.04**  
PQT |TERM.AMAR 12/10 HORQ.M6 1/4 YF556  
**REF B=9.19 REF C=9.68**

12/10"  
HORQ. M5 5/16"



**MRA-7919 REF A 18.12**  
PQT |TERM.AMAR 12/10 HORQ.M5 5/16 AAO312  
**REF B=27.58 REF C=29.03**

3/16AWG



**MRA-8000 REF A 0.11**  
PZA |TERM.ANIL.COBRE 3/16AWG 12-10 AUT  
**REF B=0.16 REF C=0.17**

1/4"  
AWG 8-6



**MRA-8005 REF A 0.2**  
PZA |TERM.ANIL.COBRE 1/4AWG 8-6 AUT  
**REF B=0.3 REF C=0.31**

3/8"  
AWG 8-10



**MRA-8015 REF A 0.2**  
PZA |TERM.ANIL.COBRE 3/8AWG 8-10 AUT  
**REF B=0.3 REF C=0.31**

3/8 AWG  
200A



**MRA-8026 REF A 5.34**  
PQT |TER.ANIL.COBR.ABIER.3/8AWG 4-2 AUTO 25P  
**REF B=8.13 REF C=8.56**



8 AWG  
100PCS



**MRA-8050 REF A 0.15**  
PZA |TERMIN.COBR.ESTA¥AD.SC10 AWG 8 1008  
**REF B=0.22 REF C=0.24**

20A  
110-220V



**MRA-8053 REF A 0.21**  
PZA |TERMIN.COBR.ESTA¥AD.SC16 AWG 6 1608  
**REF B=0.32 REF C=0.34**

4AWG  
100PCS



**MRA-8056 REF A 0.29**  
PZA |TERMIN.COBR.ESTA¥AD.SC25 AWG 4 2508  
**REF B=0.45 REF C=0.47**

**2AWG  
100PCS**



**MRA-8059 REF A 0.38**  
PZA |TERMIN.COBR.ESTA¥AD.SC35 AWG 2  
3510  
**REF B=0.58 REF C=0.61**

**1/0AWG  
50PCS**



**MRA-8062 REF A 0.71**  
PZA |TERMIN.COBR.ESTA¥A.SC50 AW 1/0  
5010  
**REF B=1.09 REF C=1.14**

**2/0AWG  
50PCS**



**MRA-8065 REF A 0.88**  
PZA |TERMIN.COBR.ESTA¥A.SC70 AW 2/0  
7012  
**REF B=1.34 REF C=1.41**

**4/0AWG  
10PCS**



**MRA-8068 REF A 1.51**  
PZA |TERMIN.COBR.ESTA¥A.SC95 AW 3/0  
9512  
**REF B=2.3 REF C=2.42**

**4/0AWG  
10PCS**



**MRA-8071 REF A 2.14**  
PZA |TERMI.COBR.ESTA¥A.SC120 A 4/0  
12014  
**REF B=3.26 REF C=3.43**

**150-250MCM  
5 PCS**



**MRA-8073 REF A 3.02**  
PZA |TER.COBR.ESTA¥A.SC150 A250MCM  
15014  
**REF B=4.6 REF C=4.84**

**350 AWG  
25PCS-SC185**



**MRA-8076 REF A 3.65**  
PZA |TER.COBR.ESTA¥A.SC185 A350MCM  
18516  
**REF B=5.56 REF C=5.85**

**500 AWG  
20PCS-SC240**



**MRA-8079 REF A 4.91**  
PZA |TER.COBR.ESTA¥A.SC240 A500MCM  
24016  
**REF B=7.48 REF C=7.87**

**4AWG-25mm  
20PCS**

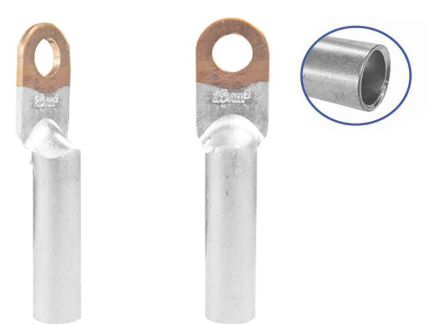

**MRA-8085 REF A 0.5**  
PZA |TERMIN.COBR.ALUMINIO TL25 AWG 4  
L25  
**REF B=0.77 REF C=0.81**



**2 AWG  
20 PCS**

**MRA-8087 REF A 0.63**  
PZA | TERMIN.COBR.ALUMINIO TL35 AWG 2  
L35  
REF B=0.96 REF C=1.01



**1/0 AWG  
20 PCS**

**MRA-8089 REF A 0.8**  
PZA | TERMIN.COBR.ALUMIN.TL50 AWG 1/0  
L50  
REF B=1.21 REF C=1.28



**2/0 AWG  
10 PCS**

**MRA-8091 REF A 1.01**  
PZA | TERMIN.COBR.ALUMIN.TL70 AWG 2/0  
L70  
REF B=1.53 REF C=1.61



**4/0 AWG  
10 PCS**

**MRA-8093 REF A 1.26**  
PZA | TERMIN.COBR.ALUMIN.TL95 AWG 4/0  
L95  
REF B=1.92 REF C=2.02



**250MCM  
10 PCS**

**MRA-8095 REF A 1.76**  
PZA | TER.COBR.ALUM.TL120 AW 250MCM  
L120  
REF B=2.68 REF C=2.83



**97PCS**

**MRA-9000 REF A 4.01**  
KIT | KIT FUSIBLE TIPO MUELA  
SURTID.97PCS  
REF B=6.1 REF C=6.42



**181pcs**

**Q7**  
**MRA-9005 REF A 6.9**  
KIT | KIT FUSIBLE T/MUELA MINI  
SURT.181PZ  
REF B=10.5 REF C=11.05



**DIESEL TOOLS**

**MRA-9007 REF A 7.01**  
KIT | KIT FUSIBLE TIPO MUELA  
SURTID.181PZ  
REF B=10.68 REF C=11.24



**240PCS**

**DIESEL TOOLS**

**MRA-9012 REF A 7.52**  
KIT | KIT REMACHES PLASTICO PRESION  
240PZ  
REF B=11.44 REF C=12.04





**MRA-9014** REF A 8.52  
 KIT | KIT REMACHES  
 PLAS.PRESION.AUTOM.415PZ  
 REF B=12.96 REF C=13.64



**620** PCS SET



**MRA-9017** REF A 8.85  
 KIT | KIT REMACHES  
 PLAS.PRES.AUTOMOT.620P  
 REF B=13.47 REF C=14.18

**2.3/4" A**  
**2.1/4"**



**MRA-9900** REF A 7.2  
 PZA | ZUNCHO PEQUENO DE 2.3/4 A 2.1/4  
 REF B=10.96 REF C=11.54



**2"**



**MRD-2260** REF A 8.35  
 PZA | EXTRACTOR T/GUILLOTIN.D/  
 ROLIN.2"050  
 REF B=12.71 REF C=13.38



**3"**



**MRD-2262** REF A 14.78  
 PZA | EXTRACTOR T/GUILLOTIN.D/  
 ROLIN.3"075  
 REF B=22.49 REF C=23.68



**4"**



**MRD-2264** REF A 27.05  
 PZA | EXTRACTOR T/GUILLOTIN.D/  
 ROLIN.4"105  
 REF B=41.18 REF C=43.34



**1/4"**  
**3"-6"-10"**



**MRD-2279** REF A 2.4  
 JGO | EXTENSION MECAN.P/RACH.1/4" 3PC  
 892  
 REF B=3.66 REF C=3.85



**1/4"**  
**3"-6"-10"**



**MRD-2280** REF A 1.97  
 JGO | EXTENSION MECAN.P/RACH.1/4" 3PC  
 471  
 REF B=3 REF C=3.16



**1/4"**  
**3"-4"-6"**



**MRD-2284** REF A 2.34  
 JGO | EXTENS.MEC.P/RACH.1/4"3P  
 3-4-6"3015  
 REF B=3.56 REF C=3.75



**3/8"**  
**3"-6"-10"**

**MRD-2315 REF A 3.46**  
JGO | EXTENSION MECAN.P/RACH.3/8" 3PC  
461  
**REF B=5.26 REF C=5.54**



**3/8"**

**MRD-2317 REF A 3.24**  
JGO | EXTENSION MECAN.P/RACH.3/8" 3PC  
6-3/8  
**REF B=4.93 REF C=5.19**



**3/8"**

**MRD-2320 REF A 3.82**  
JGO | EXTENS.MEC.P/RAC.3/8 BARR+2EXT  
2-38  
**REF B=5.82 REF C=6.13**



**1/2"**  
**3"-5"-8"**

**MRD-2360 REF A 4.48**  
JGO | EXTENSIO MECAN.P/RACHT 1/2" 3PC  
451  
**REF B=6.81 REF C=7.17**



**1/2x8"**

**MRD-2370 REF A 1.67**  
PZA | EXTENSION MECAN.P/RACHT 1/2"x  
8"DS  
**REF B=2.54 REF C=2.68**



**1/2x10"**

**MRD-2375 REF A 1.87**  
PZA | EXTENSIO MECAN.P/RACHT 1/2"x  
10"DS  
**REF B=2.85 REF C=3**



**1/4x8"**

**MRD-2385 REF A 2**  
PZA | EXTENS.N.MEC.MAGNET.FLEXIB.1/4"x8"  
00  
**REF B=3.05 REF C=3.21**



**1/2"-3/8"**  
**1/4"**

**MRD-2390 REF A 9.02**  
PZA | EXTENS.MEC.FLEX.JG 3P  
1/4"3/8"1/2"12  
**REF B=13.73 REF C=14.45**



**3/8"x8mm**  
**12Puntas**

**MRD-2445 REF A 0.79**  
PZA | DADOS 12P.CORTO CROM.3/8 X 8  
MM DS  
**REF B=1.21 REF C=1.27**



**3/8" x 10mm  
12Puntas**



**MRD-2447 REF A 0.79**  
PZA | DADOS 12P.CORTO CROM.3/8 X  
10MM DS

**REF B=1.21 REF C=1.27**

**3/8" x 8mm**



**MRD-2450 REF A 0.89**  
PZA | DADOS HEX.LARGO CROM.3/8 X 8 MM

**REF B=1.35 REF C=1.42**

**3/8" x 10mm**



**MRD-2453 REF A 0.89**  
PZA | DADOS HEX.LARGO CROM.3/8 X  
10MM

**REF B=1.35 REF C=1.42**

**3/8" x 11mm**



**MRD-2456 REF A 1.09**  
PZA | DADOS HEX.LARGO CROM.3/8 X  
11MM

**REF B=1.65 REF C=1.74**

**3/8" x 12mm**



**MRD-2459 REF A 1.09**  
PZA | DADOS HEX.LARGO CROM.3/8 X  
12MM

**REF B=1.65 REF C=1.74**

**3/8" x 13mm**



**MRD-2462 REF A 1.09**  
PZA | DADOS HEX.LARGO CROM.3/8 X  
13MM

**REF B=1.65 REF C=1.74**

**14mm**



**MRD-2465 REF A 1.09**  
PZA | DADOS HEX.LARGO CROM.3/8 X  
14MM

**REF B=1.65 REF C=1.74**

**3/8x15"**



**MRD-2468 REF A 1.27**  
PZA | DADOS HEX.LARGO CROM.3/8 X  
15MM

**REF B=1.93 REF C=2.03**

**3/8" 8-21MM**



**MRD-2483 REF A 12.78**  
JGO | DADOS LARGO 3/8 10P 8-21M  
SRUN-9021

**REF B=19.44 REF C=20.47**



**3/8"**



**MRD-2490 REF A 3.34**  
JGO | DADOS CORTO 3/8 9P 10-19M  
D10730  
REF B=5.08 REF C=5.35

**1/2"**  
**x10mm**



**MRD-2512 REF A 1.1**  
PZA | DADOS HEX.LARGO.CROM.1/2 X 10M  
REF B=1.68 REF C=1.77

**1/2"**  
**x11mm**



**MRD-2515 REF A 1.57**  
PZA | DADOS HEX.LARGO.CROM.1/2 X 11M  
REF B=2.39 REF C=2.51

**1/2"**  
**x12mm**



**MRD-2518 REF A 1.1**  
PZA | DADOS HEX.LARGO.CROM.1/2 X 12M  
REF B=1.68 REF C=1.77

**1/2"**  
**x13mm**



**MRD-2521 REF A 1.19**  
PZA | DADOS HEX.LARGO.CROM.1/2 X 13M  
REF B=1.8 REF C=1.9

**1/2"**  
**x15mm**



**MRD-2527 REF A 1.09**  
PZA | DADOS HEX.LARGO.CROM.1/2 X 15M  
REF B=1.65 REF C=1.74

**1/2"**  
**x16mm**



**MRD-2528 REF A 1.09**  
PZA | DADOS HEX.LARGO.CROM.1/2 X 16M  
REF B=1.65 REF C=1.74

**1/2"**  
**x17mm**



**MRD-2530 REF A 1.27**  
PZA | DADOS HEX.LARGO.CROM.1/2 X 17M  
REF B=1.93 REF C=2.03

**1/2"**  
**x18mm**



**MRD-2533 REF A 1.57**  
PZA | DADOS HEX.LARGO.CROM.1/2 X 18M  
REF B=2.39 REF C=2.51



**1/2"x1/2"  
12 Puntas**



**MRD-2645 REF A 1.01**  
PZA | DADOS 12PT.MEC.CROM/  
VAN.1/2X1/2" DS  
**REF B=1.53 REF C=1.61**



**1/2"x5/8"  
12Puntas**



**MRD-2648 REF A 1.01**  
PZA | DADOS 12PT.MEC.CROM/  
VAN.1/2X5/8" DS  
**REF B=1.53 REF C=1.61**



**1/2"x9/16"  
12 Puntas**



**MRD-2651 REF A 1.01**  
PZA | DADOS 12PT.MEC.CROM/  
VAN.1/2X9/16" DS  
**REF B=1.53 REF C=1.61**



**1/2"x8m**



**MRD-2670 REF A 1.04**  
PZA | DADOS 6P.MEC.CRO/VAN.1/2 X 8M  
UYUS  
**REF B=1.59 REF C=1.67**



**1/2"x9m**



**MRD-2673 REF A 1.09**  
PZA | DADOS 6P.MEC.CRO/VAN.1/2 X 9M  
UYUS  
**REF B=1.66 REF C=1.74**



**1/2"x10m**



**MRD-2677 REF A 1.09**  
PZA | DADOS 6P.MEC.CRO/VAN.1/2 X 10M  
UYUS  
**REF B=1.66 REF C=1.74**



**1/2"  
x10mm**



**MRD-2678 REF A 0.57**  
PZA | DADOS 6P.MEC.CRO/VAN.1/2 X 10M  
DS  
**REF B=0.86 REF C=0.91**



**1/2"x11m**



**MRD-2700 REF A 1.03**  
PZA | DADOS 6P.MEC.CRO/VAN.1/2X11M  
VI/UYU  
**REF B=1.57 REF C=1.65**



**1/2"  
x11mm**



**MRD-2701 REF A 0.6**  
PZA | DADOS 6P.MEC.CRO/VAN.1/2 X 11M  
DS  
**REF B=0.92 REF C=0.96**

1/2"  
x12mm



MRD-2704 REF A 0.6  
PZA | DADOS 6P.MEC.CRO/VAN.1/2 X 12M  
DS  
REF B=0.92 REF C=0.96

1/2"x13m



MRD-2707 REF A 1.12  
PZA | DADOS 6P.MEC.CRO/VAN.1/2X13M  
VI/UJU  
REF B=1.7 REF C=1.79

1/2"  
x13mm



MRD-2708 REF A 0.6  
PZA | DADOS 6P.MEC.CRO/VAN.1/2 X 13M  
DS  
REF B=0.92 REF C=0.96

1/2"  
14mm



MRD-2711 REF A 0.64  
PZA | DADOS 6P.MEC.CRO/VAN.1/2 X 14M  
DS  
REF B=0.97 REF C=1.02

1/2"x15m



MRD-2713 REF A 1.1  
PZA | DADOS 6P.MEC.CRO/VAN.1/2 X 15M  
UYUS  
REF B=1.68 REF C=1.77

1/2"  
x15mm



MRD-2714 REF A 0.64  
PZA | DADOS 6P.MEC.CRO/VAN.1/2 X 15M  
DS  
REF B=0.97 REF C=1.02

1/2"  
x27mm



MRD-2745 REF A 2.95  
PZA | DADOS 6P.MEC.CRO/VAN.1/2X27M  
VINK  
REF B=4.5 REF C=4.73

1/2"x8mm  
12Puntas



MRD-2754 REF A 0.88  
PZA | DADOS 12P.MEC.CRO/VAN.1/2 X 8 M  
DS  
REF B=1.34 REF C=1.41

1/2"x10mm  
12 Puntas



MRD-2755 REF A 0.88  
PZA | DADOS 12P.MEC.CRO/VAN.1/2 X 10M  
DS  
REF B=1.34 REF C=1.41



**1/2"x12mm  
12 Puntas**



**MRD-2756 REF A 0.88**  
PZA | DADOS 12P.MEC.CRO/VAN.1/2 X 12M DS

REF B=1.34 REF C=1.41



**1/2"  
8-21MM**



**MRD-2778 REF A 14.16**  
JGO | DADOS 6PT.9PCS LARGO 8-21M X1/2 020

REF B=21.55 REF C=22.69



**1/2"**



**MRD-2781 REF A 12.78**  
JGO | DADOS 6PT.10PCS LARG.13-24M X1/2 71

REF B=19.44 REF C=20.47



**9PCS  
E10-E24 x  
1/4, 3/8, 1/2**



**MRD-2787 REF A 7.03**  
JGO | DADOS TORK JG.9P E10 A E24 X1/2 177

REF B=10.7 REF C=11.26



**14PCS  
E4-E24 x  
1/4, 3/8, 1/2**



**MRD-2790 REF A 6.73**  
JGO | DADOS TORX.JG.14P E4 A E24 X1/2 176

REF B=10.24 REF C=10.78



**30pcs**



**MRD-2810 REF A 14.98**  
JGO | DADOS Y MACHOS TORX JGO 1/4-3/8 001

REF B=22.8 REF C=24



**3/8"xE10  
Tipo E**



**MRD-2835 REF A 1.06**  
PZA | DADOS TORX 3/8"X E10 DS3810

REF B=1.61 REF C=1.69



**3/8"xE12  
Tipo E**



**MRD-2837 REF A 1.06**  
PZA | DADOS TORX 3/8"X E12 DS3812

REF B=1.61 REF C=1.69



**3/8"xE10  
Tipo E**



**MRD-2860 REF A 0.92**  
PZA | DADOS TORX 1/2"X E10 DS1210

REF B=1.41 REF C=1.48



**1/2"xE12  
Tipo E**



**MRD-2862 REF A 0.92**  
PZA | DADOS TORX 1/2"X E12 DS1212

**REF B=1.41 REF C=1.48**



**1/4"**



**MRD-3500 REF A 7.93**  
BLT | DADO COMB.JUEGO 7p  
RAT-1/4"HM-1762

**REF B=12.07 REF C=12.7**



**1/4x3/8"**



**MRD-3510 REF A 6.11**  
JGO | DADOS SOCKET 1/4 & 3/8 40p C/P  
DIES

**REF B=9.3 REF C=9.79**



**1/4"-3/8"**



**MRD-3512 REF A 5.51**  
JGO | DADOS SOCKET 1/4&3/8 40p C/  
PL.DOBER

**REF B=8.39 REF C=8.83**



**3/8"**



**MRD-3525 REF A 11.55**  
JGO | DADOS COMB+RATCH.3/8JG 12P  
10-24M D

**REF B=17.58 REF C=18.5**



**1/2"  
8-24mm**



**MRD-3528 REF A 8.25**  
JGO | DADOS 1/2"JGO 10P  
8-24MM+PALAN.9"02

**REF B=12.56 REF C=13.22**



**1/2"  
10-24mm**



**MRD-3530 REF A 17.12**  
JGO | DADOS 1/2"JGO 12P 10-24MM+RACH  
Q743

**REF B=26.05 REF C=27.42**



**1/2"  
8-27mm**



**MRD-3550 REF A 12.85**  
JGO | DADOS 1/2" 13P 8-27M  
RACH+PAL.TR013

**REF B=19.56 REF C=20.59**



**1/2"  
8-32mm**



**MRD-3560 REF A 30.31**  
JGO | DADOS 1/2" 25P 8-32MM+RACH  
MXH0901

**REF B=46.13 REF C=48.56**





1/2" 12-32mm



**MAXI TOOLS**  
24PC SOCKET SET  
18PC 1/2" 6PT SOCKET: 8, 10, 11, 12, 13, 14, 15, 16, 17, 18, 19, 20, 21, 22, 24, 27, 30, 32MM  
2PC 1/2" EX BAR 5" 10"  
1PC 1/2" RATCHET  
1PC 1/2" BENT BOW  
1PC 1/2" 10" SLIDING BAR  
1PC 1/2" UNIVERSAL JOINT

MRD-3572 REF A 31.23

JGO | DADO. 1/2" IMPACTO 12-32  
24P+RAC. LH24

REF B=47.53 REF C=50.03



1/2" 8-32mm



**MAXI TOOLS**  
24PC SOCKET SET  
18PC 1/2" 6PT SOCKET: 8, 10, 11, 12, 13, 14, 15, 16, 17, 18, 19, 20, 21, 22, 24, 27, 30, 32MM  
2PC 1/2" EX BAR 5" 10"  
1PC 1/2" RATCHET  
1PC 1/2" BENT BOW  
1PC 1/2" 10" SLIDING BAR  
1PC 1/2" UNIVERSAL JOINT

MRD-3575 REF A 32.14

JGO | DADOS 1/2" 24P 8-32MM+RACHE  
MXG107B

REF B=48.91 REF C=51.48



1/2" 8-32mm



**MAXI TOOLS**  
24PC SOCKET SET  
18PC 1/2" 6PT SOCKET: 8, 10, 11, 12, 13, 14, 15, 16, 17, 18, 19, 20, 21, 22, 24, 27, 30, 32MM  
2PC 1/2" EX BAR 5" 10"  
1PC 1/2" RATCHET  
1PC 1/2" 10" SLIDING BAR  
1PC 1/2" UNIVERSAL JOINT  
1PC 1/2" 21MM SPART PLUG

MRD-3578 REF A 28.47

JGO | DADOS 1/2" 24P 8-32MM+RACHE  
MXG107

REF B=43.33 REF C=45.61



**MAXI TOOLS**  
25PC SOCKET SET  
18PC 1/2" 6PT SOCKET: 8, 10, 11, 12, 13, 14, 15, 16, 17, 18, 19, 20, 21, 22, 24, 27, 30, 32MM  
2PC 1/2" EX BAR 5" 10"  
1PC 1/2" RATCHET  
1PC 1/2" 10" HANDLE  
1PC 1/2" 10" SLIDING BAR  
1PC 1/2" UNIVERSAL JOINT  
1PC SCHROUWER

MRD-3581 REF A 27.55

JGO | DADOS 1/2" 25P 8-32M+RACHE  
MXH0901B

REF B=41.93 REF C=44.13



1/2" 8-24mm



MRD-3660 REF A 21.63

JGO | DADO LARG. 1/2" 10P. NEUMAT. 8-24m  
1746

REF B=32.92 REF C=34.65



1/2" 13pcs



MRD-3669 REF A 34.4

JGO | DAD. LAR. 1/2" 13P. NEUMT. 7/16-1.1/4-  
13

REF B=52.36 REF C=55.11



**DIESEL TOOLS**

MRD-3675 REF A 44.24

JGO | DAD. 1/2. LARG/  
COR. 32P. NEUMA. 8-32M-32

REF B=67.33 REF C=70.87



**MAXI TOOLS**

MRD-3690 REF A 33.06

JGO | DADOS/LLAV. 8-32M Y 8-19M 37PC  
MX037

REF B=50.31 REF C=52.96



**MAXI TOOLS**

MRD-3710 REF A 47.56

JGO | DAD. COMB+RACH. 108PC SURTIDOS  
MX901A

REF B=72.39 REF C=76.2



**3/4" a 2"**

**MRD-3750 REF A 86.52**  
**JGO | DADOS 3/4" JGO 21P**  
**3/4-2"+RATCH.Y021**  
**REF B=131.69 REF C=138.61**



**3/4" 22pcs**

**MRD-3760 REF A 127.81**  
**JGO | DADOS 3/4" JGO.22PC**  
**19-50M+RACH.3422**  
**REF B=194.52 REF C=204.74**



**1/4"-3/8" 1/4"**

**MRD-3860 REF A 5.31**  
**PZA | DADOS CARDAN JG 3PZ**  
**1/4/3/8/1/2" J03**  
**REF B=8.08 REF C=8.51**



**3/8" 5/8"-3/4"-13/16"**

**MRD-3875 REF A 2.66**  
**PZA | DAD.BUJIA 3/8 3P.5/8x13/16x23/32**  
**94**  
**REF B=4.04 REF C=4.25**



**3/16"-7/16" 5-12 mm**

**MRD-3900 REF A 1.84**  
**SET | DADO JG14PC P/TALADR.P/TUERC.M/**  
**P 14**  
**REF B=2.8 REF C=2.94**



**1/4" x6"**

**MRD-6650 REF A 3.54**  
**PZA | PALANCA DE FUERZA D-1/4" X**  
**6" DTF014**  
**REF B=5.39 REF C=5.67**



**3/8" x8"**

**MRD-6655 REF A 4.14**  
**PZA | PALANCA DE FUERZA D-3/8" X**  
**8" DTF038**  
**REF B=6.3 REF C=6.63**



**1/2"x15"**

**MRD-6700 REF A 6.88**  
**PZA | PALANCA FUERZA ARTIC.1/2"X15**  
**DTFH12**  
**REF B=10.47 REF C=11.02**



**1/2"x18"**

**MRD-6710 REF A 10.22**  
**PZA | PALANCA DE FUERZA D-1/2" X 18" Q7**  
**REF B=15.56 REF C=16.37**



1/2"x24"



MRD-6717 REF A 16.45  
PZA | PALANC. FUERZA  
ARTICULAD. 1/2"X24"006  
REF B=25.03 REF C=26.35



3/4"x19mm  
x500mm



MRD-6770 REF A 10.75  
PZA | PALANCA D/FUERZA 3/4X19MX500M  
DS419  
REF B=16.36 REF C=17.22



1/4"

MRD-7150 REF A 3.82  
PZA | RATCHET 1/4 MAGO GOMA CROMADO  
REF B=5.82 REF C=6.13



3/8x1/2"



MRD-7210 REF A 4.79  
PZA | RATCHET 3/8 X 1/2 CORTO DIESEL  
072  
REF B=7.29 REF C=7.68



3/8x1/2"



MRD-7220 REF A 7.65  
PZA | RATCHET 3/8 X 1/2 LARGO DIESEL  
0073  
REF B=11.64 REF C=12.25



1/2"



MRD-7285 REF A 4.53  
PZA | RATCHET 1/2" MANG./GOM. CROM DT-  
TL001  
REF B=6.89 REF C=7.25



4" x  
2.5mm



MTR-6002 REF A 0.3  
PQT | CINTA AMARRE BLANC  
100mm(4")x2.5mm  
REF B=0.46 REF C=0.48



2.5x150mm



MTR-6004 REF A 0.38  
PQT | CINTA AMARRE BLANC  
150mm(6")x2.5mm  
REF B=0.58 REF C=0.62



8" x  
2.5mm



MTR-6006 REF A 0.78  
PQT | CINTA AMARRE BLANC  
200mm(8")x2.5mm  
REF B=1.19 REF C=1.26

**6" x 3.6mm**



**MTR-7144 REF A 0.7**  
PQT |CINTA AMARRE BLANC  
150mm(6")x3.6mm  
**REF B=1.07 REF C=1.12**

**8" x 3.6mm**



**MTR-7146 REF A 0.9**  
PQT |CINTA AMARRE BLANC  
200mm(8")x3.6mm  
**REF B=1.37 REF C=1.44**

**10" x 3.6mm**



**MTR-7148 REF A 1.27**  
PQT |CINTA AMARRE BLANC  
250mm(10")x3.6mm  
**REF B=1.94 REF C=2.04**

**12" x 3.6mm**

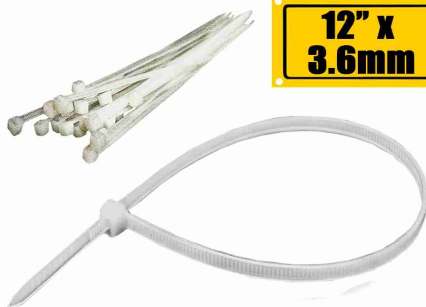

**MTR-7150 REF A 1.27**  
PQT |CINTA AMARRE BLANC  
300mm(12")x3.6mm  
**REF B=1.93 REF C=2.03**

**10" x 4.8mm**



**MTR-7308 REF A 1.37**  
PQT |CINTA AMARRE BLANC  
250mm(10")x4.8mm  
**REF B=2.08 REF C=2.19**

**12" x 4.8mm**



**MTR-7310 REF A 1.7**  
PQT |CINTA AMARRE BLANC  
300mm(12")x4.8mm  
**REF B=2.59 REF C=2.73**

**14" x 4.8mm**



**MTR-7312 REF A 1.97**  
PQT |CINTA AMARRE BLANC  
350mm(14")x4.8mm  
**REF B=3 REF C=3.16**

**4.8x400 mm**



**MTR-7314 REF A 2.4**  
PQT |CINTA AMARRE BLANC  
400mm(16")x4.8mm  
**REF B=3.66 REF C=3.85**

**20" x 4.8mm**



**MTR-7318 REF A 3.64**  
PQT |CINTA AMARRE BLANC  
500mm(20")x4.8mm  
**REF B=5.54 REF C=5.83**

**20"**  
**x7mm**

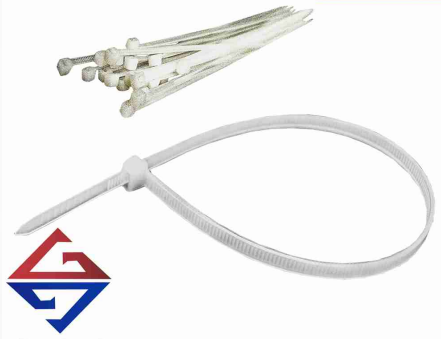

**MTR-7388 REF A 4.34**  
PQT |CINTA.AMAR.BLAN.500mm 20"x7.0mm  
P/50  
**REF B=6.61 REF C=6.96**

**14"**  
**x7.6MM**



**MTR-7422 REF A 4.34**  
PQT |CINTA AMARRE BLANC  
350mm(14")x7.6mm  
**REF B=6.61 REF C=6.96**

**16"**  
**x7.6MM**

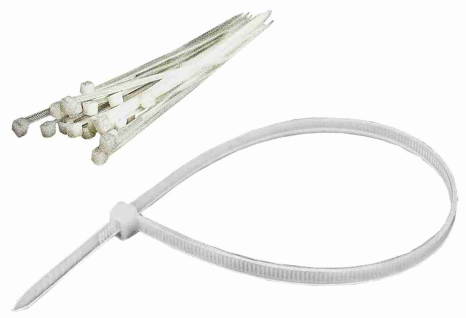

**MTR-7424 REF A 4.91**  
PQT |CINTA AMARRE BLANC  
400mm(16")x7.6mm  
**REF B=7.47 REF C=7.87**

**6"**  
**x2.5MM**



**MTR-7504 REF A 0.38**  
PQT |CINTA AMARRE NEGRO  
150mm( 6")x2.5mm  
**REF B=0.58 REF C=0.62**

**8" x**  
**2.5mm**



**MTR-7506 REF A 0.78**  
PQT |CINTA AMARRE NEGRO  
200mm( 8")x2.5mm  
**REF B=1.19 REF C=1.26**

**6"**  
**x3.6mm**



**MTR-7644 REF A 0.7**  
PQT |CINTA AMARRE NEGRO  
150mm( 6")x3.6mm  
**REF B=1.07 REF C=1.12**

**8" x**  
**3.6mm**



**MTR-7646 REF A 0.9**  
PQT |CINTA AMARRE NEGRO  
200mm( 8")x3.6mm  
**REF B=1.37 REF C=1.44**

**10"**  
**x3.6MM**



**MTR-7648 REF A 1.09**  
PQT |CINTA AMARRE NEGRO  
250mm(10")x3.6mm  
**REF B=1.65 REF C=1.74**

**12" x**  
**3.6mm**



**MTR-7650 REF A 1.27**  
PQT |CINTA AMARRE NEGRO  
300mm(12")x3.6mm  
**REF B=1.93 REF C=2.03**

18" x  
4.2m



**Voltage**  
electronics part

MTR-7716 REF A 4.43  
PQT |CINTA AMARRE NEGRO  
450mm(18")x4.2mm  
REF B=6.74 REF C=7.09

10"  
x4.8MM



  
GDSEO

MTR-7838 REF A 1.37  
PQT |CINTA AMARRE NEGRO  
250mm(10")x4.8mm  
REF B=2.08 REF C=2.19

12" x  
4.8m



MTR-7840 REF A 1.7  
PQT |CINTA AMARRE NEGRO  
300mm(12")x4.8mm  
REF B=2.59 REF C=2.73

14"  
x4.8MM





MTR-7842 REF A 1.97  
PQT |CINTA AMARRE NEGRO  
350mm(14")x4.8mm  
REF B=3 REF C=3.16

16"  
x4.8mm



MTR-7844 REF A 2.4  
PQT |CINTA AMARRE NEGRO  
400mm(16")x4.8mm  
REF B=3.66 REF C=3.85

20"  
x4.8mm





MTR-7848 REF A 3.64  
PQT |CINTA AMARRE NEGRO  
500mm(20")x4.8mm  
REF B=5.54 REF C=5.83

14" x  
7.7m





MTR-8062 REF A 4.34  
PQT |CINTA AMARRE NEGRO  
350mm(14")x7.6mm  
REF B=6.61 REF C=6.96

18"  
x8MM





MTR-8116 REF A 4.91  
PQT |CINTA AMARRE NEGRO  
450mm(18")x8.0mm  
REF B=7.47 REF C=7.87

S-5  
50GR





PEG-0840 REF A 3.23  
PZA |S.5 ACERO PLASTICO DEVCON  
REF B=4.91 REF C=5.17



**EPOXY BLANCO  
2TON**



**Devcon.**

PEG-0850 REF A 3  
PZA |S.30 ACERO PLAST.2 TONELADA  
DEVCON  
REF B=4.57 REF C=4.81



**30gr**



**Q7**

PEG-1670 REF A 1.22  
PZA |COLA CEMENTO CONTACTO  
ZAPAT.30GR Q7  
REF B=1.86 REF C=1.95

**3/4"x20M**



**DIESEL TOOLS**

PEG-7030 REF A 0.47  
PZA |TIRRO D/ENMASCARAR 3/4X20MT  
DIE.2034  
REF B=0.71 REF C=0.75

**1"x20M**



**Q7**

PEG-7033 REF A 0.72  
PZA |TIRRO D/ENMASCARAR 1" X 20mts  
Q7  
REF B=1.09 REF C=1.15

**2"x20Mts**



**Q7**

PEG-7035 REF A 1.22  
PZA |TIRRO D/ENMASCARAR 2" X 20mts  
Q7  
REF B=1.86 REF C=1.95

**3/4"x  
30MTS**



**celoven c.a.**

PEG-7049 REF A 1.4  
PZA |3440 TIRR.CELOVEN 3/4"X30mt  
REF B=2.13 REF C=2.24

**3/4"x  
45MTS**



**celoven c.a.**

PEG-7050 REF A 1.87  
PZA |3450 TIRRO CELOVEN 3/4X45mt  
REF B=2.84 REF C=2.99

**2"x  
45MTS**



**celoven c.a.**

PEG-7080 REF A 4.65  
PZA |2150 TIRRO CELOVEN 2X45MT  
REF B=7.08 REF C=7.45

**3/4"x  
55MTS**



**celoven c.a.**

PEG-7082 REF A 2.67  
PZA |3455A TIRRO CELV.AZUL 3/4X55Mt  
REF B=4.06 REF C=4.28

**3/4"x  
55MTS**



**celoven** c.a.

**PEG-7083 REF A 2.73**  
PZA | 3455V TIR.CEL.AUT.VERD.3/4X55M  
**REF B=4.16 REF C=4.37**

**10ml**



**DIESEL TOOLS**

**PEG-7110 REF A 0.78**  
PZA | TRABA ROSCA ADHESIV.FIJACION  
10ML DT  
**REF B=1.19 REF C=1.26**

**2"x92M**



**PEG-7150 REF A 0.64**  
PZA | CINTA POLIPRO.MARRON.2"x92MT  
TA-100  
**REF B=0.97 REF C=1.02**

**45mm  
x458M**



**DOBERMAN**

**PEG-7156 REF A 2.86**  
PZA | CINTA POLIPR.TRANS.45MMX458MT  
DOBER  
**REF B=4.35 REF C=4.57**

**300ml**



**ZASC**

**PEG-8992 REF A 2.74**  
PZA | SILICON USO GRAL NEGRO ZASC  
300ML  
**REF B=4.17 REF C=4.39**

**310ml**



**ZASC**

**PEG-9004 REF A 4.18**  
PZA | SELLADOR POLIURETANO NEGR.ZASC  
310ML  
**REF B=6.35 REF C=6.69**

**85ml**



**ZASC**

**PEG-9020 REF A 1.2**  
PZA | SILICON RTV ZASC NEGRO 85 ML  
**REF B=1.83 REF C=1.93**

**85gr**



**Q7**

**PEG-9022 REF A 1.27**  
PZA | SILICON RTV NEGRO.ALT/TEMP 85GRS  
Q7  
**REF B=1.93 REF C=2.03**

**72ML**



**PERMAFLEX**

**PEG-9025 REF A 1.62**  
PZA | SILICON PERMAFLEX GRIS TEMP 72 ML  
**REF B=2.46 REF C=2.59**





**85gr**



**PEG-9027 REF A 1.47**  
PZA | SILICON GRIS.HI-TEMP.GREY 999 85GRS  
**REF B=2.24 REF C=2.35**



**85gr**



**PEG-9030 REF A 1.26**  
PZA | SILICON DIESEL TOOLS ROJO 85 GRs  
**REF B=1.92 REF C=2.02**



**400ml**

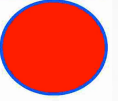

**ZASC**

**PIN-5506 REF A 1.95**  
PZA | PINT.SPRAY TORONJA 400 ML ZASC  
**REF B=2.96 REF C=3.12**



**ZASC**

**PIN-5509 REF A 2.55**  
PZA | PINT.SPRAY DORADO 400M #R-3049 ZASC  
**REF B=3.89 REF C=4.09**



**400ml**

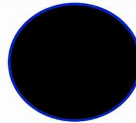

**ZASC**

**PIN-5528 REF A 1.95**  
PZA | PINT.SPRAY NEGRO MATE 400 ML ZASC  
**REF B=2.96 REF C=3.12**



**400ML**

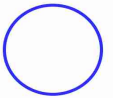

**ZASC**

**PIN-5544 REF A 1.85**  
PZA | PINT.SPR.BLANC.BRILLAN.400M #40 ZAS  
**REF B=2.82 REF C=2.97**



**400ml**

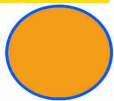

**ZASC**

**PIN-5561 REF A 1.95**  
PZA | PINT.SPR.AMARILL.OSCUR.400M #31 ZAS  
**REF B=2.96 REF C=3.12**



**400ml**

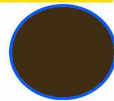

**ZASC**

**PIN-5568 REF A 1.95**  
PZA | PINT.SPRAY CHOCOLATE 400ML #135 ZAS  
**REF B=2.96 REF C=3.12**



**400ml**

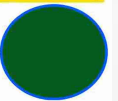

**ZASC**

**PIN-5582 REF A 1.95**  
PZA | PINT.SPRAY VERDE CLARO 400 ML ZASC  
**REF B=2.96 REF C=3.12**



400ml  
N° 37



**PIN-5584 REF A 1.86**  
PZA | PINT.SPRAY VERDE CLARO.400ML #37  
Q7  
REF B=2.83 REF C=2.98



400ML  
N°101



**ZASC**

**PIN-5586 REF A 1.95**  
PZA | PINT.SPRAY VERDE JADE 400M #101  
ZAS  
REF B=2.96 REF C=3.12



400ml

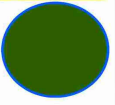

**ZASC**

**PIN-5587 REF A 1.95**  
PZA | PINT.SPRA.VERDE IRLANDES 400ML  
ZASC  
REF B=2.96 REF C=3.12



400ml



**ZASC**

**PIN-5590 REF A 1.95**  
PZA | PINT.SPRAY AZUL MARINO 400 ML  
ZASC  
REF B=2.96 REF C=3.12



400ml



**ZASC**

**PIN-5592 REF A 1.95**  
PZA | PINT.SPRA.AZUL DIAMANT.400M  
#133 ZA  
REF B=2.96 REF C=3.12



400ml



**ZASC**

**PIN-5593 REF A 1.95**  
PZA | PINT.SPR.AZUL TRASLUCIDO 400ML  
ZASC  
REF B=2.96 REF C=3.12



400ml

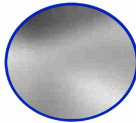

**ZASC**

**PIN-5597 REF A 2.55**  
PZA | PINT.SPRAY PLATEADO 400 ML  
ZASC  
REF B=3.89 REF C=4.09



**ZASC**

**PIN-5600 REF A 1.95**  
PZA | PINT.SPRAY ALUMINIO 400 ML #36  
ZASC  
REF B=2.96 REF C=3.12



400ML



**ZASC**

**PIN-5603 REF A 1.95**  
PZA | PINT.SPRAY GRIS BASE 400ML #98  
ZASC  
REF B=2.96 REF C=3.12



**400ml**  
**TRANSPARENTE**

**ZASC**

**PIN-5610 REF A 1.95**  
PZA |PINT.SPR.TRANSP.BRILL.400M #190  
ZAS  
**REF B=2.96 REF C=3.12**



**400ml**  
**TRANSPARENTE**

**ZASC**

**PIN-5613 REF A 1.95**  
PZA |PINT.SPR.TRANSPARE.MATE 400 ML  
ZASC  
**REF B=2.96 REF C=3.12**



**400ml**  
**NEON**

**ZASC**

**PIN-5619 REF A 3.56**  
PZA |PINT.SPRAY ROSADO NEON 400 ML  
ZASC  
**REF B=5.41 REF C=5.7**



**ALTA TEMPERATURA**  
**400ML**

**ZASC**

**PIN-5627 REF A 3.62**  
PZA |PINT.SPRAY NEGRO ALTA TEMP.400M  
ZASC  
**REF B=5.51 REF C=5.8**



**ALTA TEMPERATURA**  
**400ML**

**ZASC**

**PIN-5631 REF A 3.62**  
PZA |PINT.SPRAY PLATED.ALTA TEMP.400M  
ZAS  
**REF B=5.51 REF C=5.8**



**134A**  
**36"**

**REF-4900 REF A 16.88**  
PZA |MANG.CARGA FREON 134A 36"P/  
MANIFOR  
**REF B=25.7 REF C=27.05**



**134A**  
**60"**

**REF-4901 REF A 31.05**  
PTQ |MANG.CARGA FREON 134A 60"P/  
MANIFO.  
**REF B=47.26 REF C=49.75**



**R12-22-502**  
**36"**

**REF-4904 REF A 18.48**  
PTQ |MANG.CARG FREO.R12-22-502 36"P/  
MAN  
**REF B=28.13 REF C=29.6**



**R22-R12**  
**R502**

**REF-5005 REF A 50.92**  
PZA |MANIFOL/FREO.R22/R12/R502  
WELDTECH  
**REF B=77.5 REF C=81.57**

**weldtech**

**0-500Psi  
2.1/2"**

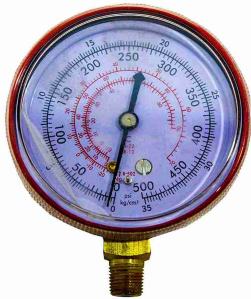

**REF-6206 REF A 4.97**  
PZA |MAN.ALT/MAN.R12-22-502  
0-500P2.1/2  
**REF B=7.56 REF C=7.96**

**1400/1500PSI  
GR-38**

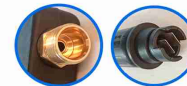

**REP-5555 REF A 7.11**  
PZA |PISTOLA HIDROJET 1400/1500PSI  
GR-38  
**REF B=10.83 REF C=11.4**

**REP-0990 REF A 5.57**  
PZA |CARBONES P/HIDROLIMPIADOR  
MHT-7939  
**REF B=8.48 REF C=8.93**

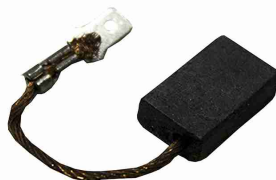

**1/2"x10M**



**REP-7010 REF A 9.27**  
PZA |RODAMIENTO P/  
HIDROLIMP.MHT-7939/41  
**REF B=14.11 REF C=14.85**

**60A**



**REP-7825 REF A 6.92**  
PZA |TERMICO MAQUINA SOLDAR 128|C  
60A  
**REF B=10.54 REF C=11.09**



**RLB-0030 REF A 1.11**  
PZA |ACOPLE PARA LICUADORA  
**REF B=1.69 REF C=1.78**

**PARA  
REGINA**



**RLB-0040 REF A 3.84**  
PZA |AGITADOR DE LAVADORA REGINA  
**REF B=5.84 REF C=6.14**

**PARA  
DAKA**



**RLB-0050 REF A 0.57**  
PZA |AMORTIGUADOR LAV.DAKA  
**REF B=0.87 REF C=0.92**

**PARA  
OSTER**



**RLB-0180 REF A 0.11**  
PZA |BASE DE CUADRANTE P/LICUADORA  
OSTER  
**REF B=0.16 REF C=0.17**

**PARA DAKA  
14mm**



**RLB-0210 REF A 0.79**  
PZA |BOYA BOCINA 14M P/LAVADOR DAKA  
UNI  
**REF B=1.2 REF C=1.26**

**14mm  
ROSCA UNIV.**



**RLB-0220 REF A 0.86**  
PZA |BOYA BOCINA 14M P/LAVADO  
ROSCA.UNI  
**REF B=1.31 REF C=1.38**

**10mm**



**RLB-0230 REF A 0.56**  
PZA |BOCIN.BRONCE P/MOTOR  
EXPRIMIDOR 10M  
**REF B=0.85 REF C=0.9**

**35w-R**

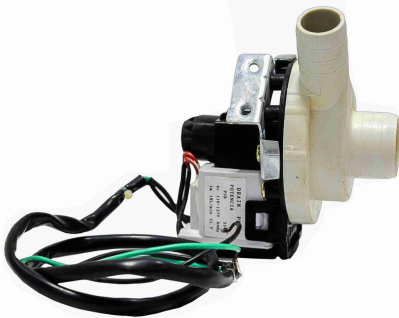

**RLB-0250 REF A 18.72**  
PZA |BOMBA 35w P/DESAGUE LAVADOR  
DAKA R  
**REF B=28.5 REF C=30**

**35w-L**



**RLB-0255 REF A 18.72**  
PZA |BOMBA 35w P/DESAGUE LAVADOR  
DAKA L  
**REF B=28.5 REF C=30**

**85w-L**

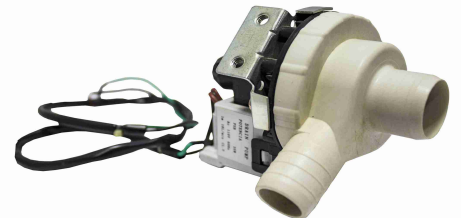

**RLB-0257 REF A 17.12**  
PZA |BOMBA 85w P/DESAGUE LAVADORA  
**REF B=26.06 REF C=27.43**

**18mm**

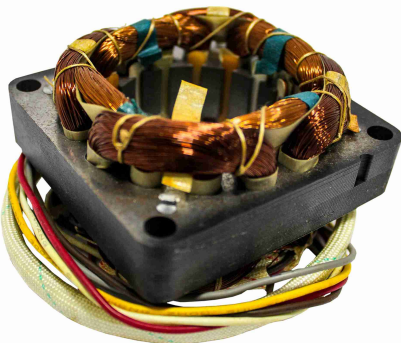

**RLB-0272 REF A 7.75**  
PZA |BOBINA VENTILADOR MET.CUADRADA  
18MM  
**REF B=11.79 REF C=12.41**

**25mm**

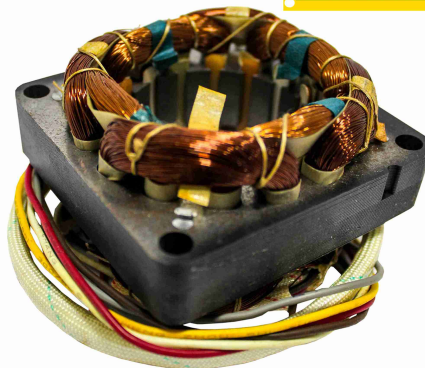

**RLB-0274 REF A 7.75**  
PZA |BOBINA VENTILADOR MET.CUADRADA  
25MM  
**REF B=11.79 REF C=12.41**

**18mm**

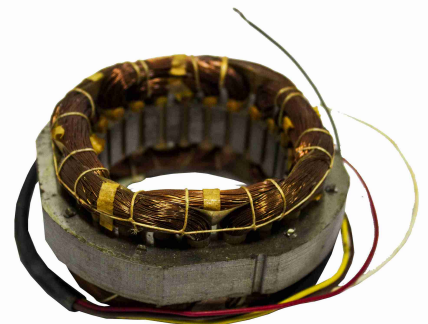

**RLB-0280 REF A 2.78**  
PZA |BOBINA VENTILADOR MET.REDONDA  
18MM  
**REF B=4.23 REF C=4.45**

**PARA LG  
15x11mm**



**RLB-0291 REF A 1.3**  
PZA |BUJE AGITADOR LAV.T/LG 15MM X  
11MM  
**REF B=1.98 REF C=2.08**

**PARA LG  
11x11mm**



**RLB-0292 REF A 1.36**  
PZA |BUJE AGITADOR LAV.T/LG 11MM X  
11MM  
**REF B=2.07 REF C=2.18**

**13D**



**RLB-0295 REF A 1.36**  
PZA |BUJE AGITADOR LAV.EJE CUADRADO  
13D  
**REF B=2.07 REF C=2.18**

**#14 600v  
250c 50Mts**

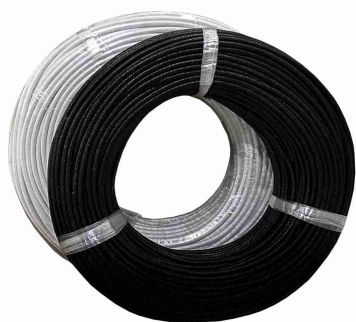

**RLB-0325 REF A 49.09**  
RLL | CABLE AMIANTO #14 600V 250C 50  
MTS  
**REF B=74.72 REF C=78.65**

**#14 600V  
250C**

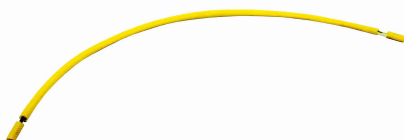

**RLB-0327 REF A 0.2**  
UND |CABLE AMIANTO #14 600V 250C DE  
25CM  
**REF B=0.31 REF C=0.33**



**RLB-0335 REF A 4.21**  
PQT |CAB/AMIANT:TERMINAL BANDERA  
CR.100P  
**REF B=6.41 REF C=6.75**

**PARA  
OSTER**



**RLB-0337 REF A 4.21**  
PQT |CAB/AMIANT:TERM.RECTOS AZUL  
CR.100P  
**REF B=6.41 REF C=6.75**

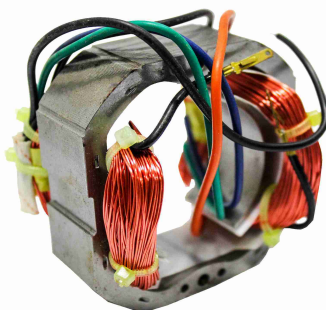

**RLB-0387 REF A 12.59**  
PZA |CAMPO(ESTARTOR)/LICUADORA  
OSTER  
**REF B=19.17 REF C=20.17**

**PARA LG  
M-33**



**RLB-0412 REF A 0.62**  
PZA |CORREA P/LAVADORA LG M33  
**REF B=0.94 REF C=0.99**

**M-30.5**



**RLB-0416 REF A 0.62**  
PZA |CORREA P/LAVADORA 30.5 M30.5

**REF B=0.94 REF C=0.99**



**RLB-0418 REF A 0.62**  
PZA |CORREA P/LAVADORA A635

**REF B=0.94 REF C=0.99**



**RLB-0420 REF A 0.62**  
PZA |CORREA P/LAVADORA O650

**REF B=0.94 REF C=0.99**



**RLB-0424 REF A 0.62**  
PZA |CORREA P/LAVADORA M24

**REF B=0.94 REF C=0.99**



**RLB-0430 REF A 0.62**  
PZA |CORREA P/LAVADORA M25

**REF B=0.94 REF C=0.99**

**PARA  
BLACK DECKER**



**RLB-0452 REF A 3.9**  
PZA |CUCHILLA P/LICUAD.T/BLACK DECKER

**REF B=5.93 REF C=6.24**

**TIPO  
OSTER**



**RLB-0455 REF A 0.17**  
PZA |CUADRANTE PARA LICUADORA T/  
OSTER

**REF B=0.25 REF C=0.27**

**PARA  
OSTER**

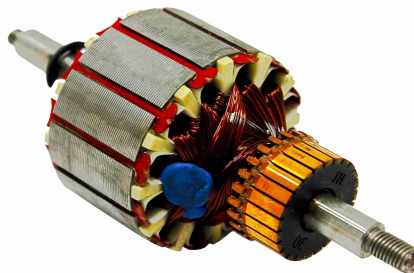

**RLB-3000 REF A 27.23**  
PZA |INDUCIDO(ROTOR) P/LICUADORA  
OSTER

**REF B=41.44 REF C=43.61**

**PARA  
OSTER**



**RLB-5015 REF A 16.9**  
PZA |MOTOR P/LICUADORA OSTER

**REF B=25.72 REF C=27.07**



**10-11  
DIENTES**

**RLB-6000 REF A 1.04**  
PZA | POLEA LAVADORA DE 10 Y 11 DIENTE  
**REF B=1.59 REF C=1.67**



**PARA  
REGINA**

**RLB-6005 REF A 1.04**  
PZA | POLEA LAVADORA REGINA  
**REF B=1.59 REF C=1.67**



**PARA  
ELECTROLUX**

**RLB-6010 REF A 1.04**  
PZA | POLEA LAVADORA ELECTROLUX  
**REF B=1.59 REF C=1.67**



**PARA  
HAIER**

**RLB-6015 REF A 1.04**  
PZA | POLEA LAVADORA HAIER  
**REF B=1.59 REF C=1.67**



**TIPO  
OSTER**

**RLB-7100 REF A 0.94**  
PZA | ROSCA VASO LICUADORA T/OSTER  
**REF B=1.42 REF C=1.5**



**TIPO  
OSTER**

**RLB-7300 REF A 2.07**  
PZA | SWITCH PARA LICUADORA OSTER  
**REF B=3.15 REF C=3.31**



**TIPO  
OSTER**

**Osterizer**  
**RLB-7650 REF A 1.8**  
PZA | TAPA LICUADORA T/OSTER  
**REF B=2.74 REF C=2.88**



**DXT15, 110-127V  
7 A 60Hz**

**RLB-7682 REF A 2.61**  
PZA | TIME P/LAVADORA 7 CABLE C/SWITCH  
**REF B=3.98 REF C=4.18**

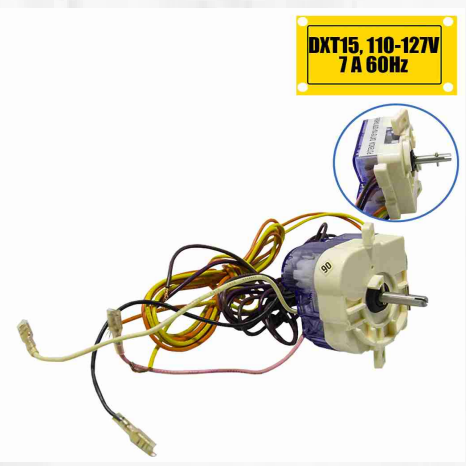

**DXT15, 110-127V  
7 A 60Hz**

**RLB-7684 REF A 2.61**  
PZA | TIME P/LAVADORA 7 CABLE  
INCLINADO  
**REF B=3.98 REF C=4.18**



**16Amp**



**RLB-7690 REF A 2.04**  
PZA | TERMOSTATO P/COCHINA ELECTRICA  
16AMP

**REF B=3.1 REF C=3.27**

**PARA G.P  
11 DIENTES**



**RLB-7720 REF A 6.46**  
PZA | TRANSMISION LAV.GP 11 DT EJE  
REDOND

**REF B=9.84 REF C=10.35**

**LG-20P**



**RLB-7725 REF A 4.29**  
PZA | TRANSMIS.LAV.LG-20 P-SHSFT-LG E/  
RED

**REF B=6.53 REF C=6.87**

**TIPO  
OSTER**



**RLB-8000 REF A 3.92**  
PZA | VASO/LICUADOR.T/OSTER VIDRIO PZA

**REF B=5.97 REF C=6.29**

**3/4"  
P-204**



**DIESEL TOOLS**

**RLN-1000 REF A 4.62**  
PZA | CHUMACERA 3/4" 232421 P204/12

**REF B=7.03 REF C=7.4**

**1"  
P-205**



**DIESEL TOOLS**

**RLN-1005 REF A 5.15**  
PZA | CHUMACERA 1" 232422 P205/16

**REF B=7.84 REF C=8.25**

**3/8"  
NC16**



**DIESEL TOOLS**

**RLN-1010 REF A 6.86**  
PZA | CHUMACERA 1.1/4"232423 P206/20

**REF B=10.45 REF C=11**

**1 1/2"  
P208**



**DIESEL TOOLS**

**RLN-1015 REF A 11.09**  
PZA | CHUMACERA 1.1/2"232424 P208/24

**REF B=16.88 REF C=17.76**

**2"  
P210**



**DIESEL TOOLS**

**RLN-1020 REF A 15.18**  
PZA | CHUMACERA 2" 232425 P210/32

**REF B=23.1 REF C=24.32**

**608.2RS.C3**



**HLB**  
Famous Trademark

**RLN-2000 REF A 0.65**  
PZA | RODAMIENTO JAPAN HLB 608.2RS.C3  
**REF B=0.99 REF C=1.05**

**608RS**



**RLN-2002 REF A 0.49**  
PZA | RODAMIENTO TURBO 608.2RS.C3  
TURBO  
**REF B=0.75 REF C=0.79**

**608.ZZ.C3**



**HLB**  
Famous Trademark

**RLN-2010 REF A 0.65**  
PZA | RODAMIENTO JAPAN HLB 608.ZZ C3  
**REF B=0.99 REF C=1.05**

**6005.2RS.C3**



**HLB**  
Famous Trademark

**RLN-4100 REF A 2.07**  
PZA | RODAMIENTO JAPAN HLB 6005.2RS.C3  
**REF B=3.15 REF C=3.31**

**6200.2RS.C3**



**HLB**  
Famous Trademark

**RLN-4200 REF A 0.78**  
PZA | RODAMIENTO JAPAN HLB 6200.2RS.C3  
**REF B=1.18 REF C=1.24**

**6201.2RS.C3**



**HLB**  
Famous Trademark

**RLN-4295 REF A 0.78**  
PZA | RODAMIENTO JAPAN HLB 6201.2RS.C3  
**REF B=1.18 REF C=1.24**

**6201.ZZ.C3**



**HLB**  
Famous Trademark

**RLN-4298 REF A 0.78**  
PZA | RODAMIENTO JAPAN HLB 6201.ZZ.C3  
**REF B=1.18 REF C=1.24**

**6201.1/2  
2RS.C3**



**HLB**  
Famous Trademark

**RLN-4305 REF A 1.23**  
PZA | RODAMIENT JAPAN HLB  
6201.1/2.2RS.C3  
**REF B=1.87 REF C=1.97**

**6202.2RS.C3**



**HLB**  
Famous Trademark

**RLN-4385 REF A 1.29**  
PZA | RODAMIENTO JAPAN HLB 6202.2RS.C3  
**REF B=1.97 REF C=2.07**

**6202.ZZ.C3**



**HLB**  
Famous Trademark

**RLN-4388 REF A 1.29**  
PZA | RODAMIENTO JAPAN HLB 6202.ZZ.C3

**REF B=1.97 REF C=2.07**

**6203.2RS.C3**



**HLB**  
Famous Trademark

**RLN-4498 REF A 1.29**  
PZA | RODAMIENTO JAPAN HLB 6203.2RS.C3

**REF B=1.97 REF C=2.07**

**6203.ZZ.C3**

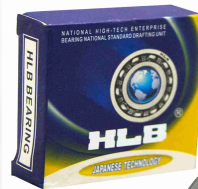

**HLB**  
Famous Trademark

**RLN-4500 REF A 1.29**  
PZA | RODAMIENTO JAPAN HLB 6203.ZZ.C3

**REF B=1.97 REF C=2.07**

**6301.ZZ.C3**



**HLB**  
Famous Trademark

**RLN-4800 REF A 1.11**  
PZA | RODAMIENTO JAPAN HLB 6301.ZZ.C3

**REF B=1.69 REF C=1.78**

**6303.2RS.C3**



**HLB**  
Famous Trademark

**RLN-4898 REF A 2.22**  
PZA | RODAMIENTO JAPAN HLB 6303.2RS.C3

**REF B=3.38 REF C=3.56**

**6304.2RS.C3**



**HLB**  
Famous Trademark

**RLN-5000 REF A 2.51**  
PZA | RODAMIENTO JAPAN HLB 6304.2RS.C3

**REF B=3.82 REF C=4.02**

**6305.ZZ.C3**



**HLB**  
Famous Trademark

**RLN-5100 REF A 3.31**  
PZA | RODAMIENTO JAPAN HLB 6305.ZZ.C3

**REF B=5.04 REF C=5.31**



**HLB**  
Famous Trademark

**RLN-5200 REF A 4.29**  
PZA | RODAMIENTO JAPAN HLB 6306.ZZ.C3

**REF B=6.52 REF C=6.87**



**HLB**  
Famous Trademark

**RLN-5300 REF A 5.62**  
PZA | RODAMIENTO JAPAN HLB 6307.2RS.C3

**REF B=8.56 REF C=9.01**

6310.2RS.C3



**HLB**  
Famous Trademark

RLN-5600 REF A 10.59  
PZA | RODAMIENTO JAPAN HLB 6310.2RS.C3

REF B=16.12 REF C=16.97



RPG-8353 REF A 9.53  
PZA | VASTAGO DUCHA 12EST  
HIDROS.CORTO

REF B=14.5 REF C=15.26



10"

RUE-2062 REF A 2.04  
PZA | TRIPA P/CAUCHO ZORRA  
10"GUSAN.EN L

REF B=3.11 REF C=3.27

7cc



SAG-0110 REF A 25.42  
PZA | AEROGRAFO PROF.7cc ARTE GRAFICA  
MA

REF B=38.68 REF C=40.72



SAG-0300 REF A 4.59  
PZA | ENVASE PLAST.P/P.DE  
GRAVED.M:M990

REF B=6.98 REF C=7.35

1/2"



SAG-0405 REF A 29.94  
PZA | FILTRO REG P/AIRE D/COMPRES.1/2  
NPT

REF B=45.57 REF C=47.97

14PCS



SAG-0757 REF A 7.62  
KIT | KIT 14 PZ P/COMPRESOR AIRE DIES-  
K01

REF B=11.59 REF C=12.2



SAG-0760 REF A 21.63  
KIT | KIT 14 PZA P/COMPRESOR AIRE MT-  
K14

REF B=32.92 REF C=34.65



SAG-0761 REF A 17.3  
KIT | KIT 20 PZA P/COMPRESOR AIRE MT-  
K20

REF B=26.33 REF C=27.72



**SAG-0762** REF A 13.16  
 KIT | MEDIDOR CAUCHO C/KIT NEUMATICO  
 17PCS  
 REF B=20.02 REF C=21.08



**SAG-0765** REF A 27.52  
 JGO | KIT PINT(PIST,AIRE,P/  
 DUCH,MAG)5pzDS  
 REF B=41.89 REF C=44.09



**SAG-0787** REF A 15.73  
 PZA | PISTOLA P/PETROLEAR ROSSI DG-10W  
 REF B=23.94 REF C=25.2



**SAG-0790** REF A 11.79  
 PZA | PISTOLA PETROLER.ROJO/FERM DO-10  
 REF B=17.94 REF C=18.89



**SAG-0795** REF A 15.53  
 PZA | PIST.PINTAR.B/PRESION 750M ROS/  
 CROW  
 REF B=23.64 REF C=24.88



**SAG-0804** REF A 32.03  
 PZA | PIST.PINTAR PROF.ALT/PRES.FMT P-07  
 REF B=48.75 REF C=51.31



**SAG-0807** REF A 29.28  
 PZA | PIST.PINT.PROF.T/SG.NA2011 C/  
 KIT.PA  
 REF B=44.57 REF C=46.91



**SAG-0810** REF A 34.12  
 PZA | PISTOL.PINT.PROF.T/SAGOLA 4001  
 ROSS  
 REF B=51.93 REF C=54.66



**SAG-0813** REF A 13.38  
 PZA | PIST.PINTAR GRAVEDAD 200ML  
 ALUM.CROW  
 REF B=20.36 REF C=21.43



**SAG-0815** REF A 19.46  
 PZA | PISTOLA PINTAR D/GRAVEDA.S990G  
 ROS  
 REF B=29.61 REF C=31.17



**600ML**



**SAG-0817** REF A 26.54  
 PZA | PIST.PINTAR.GRAVEDAD.PLAST.600ML  
 CRO  
 REF B=40.39 REF C=42.51



**SAG-0900** REF A 4.4  
 PZA | PISTOLA P/SOPLAR AIRE ITALIA F.G  
 REF B=6.69 REF C=7.04



**1/4"**



**SAG-0902** REF A 2.45  
 PZA | PIST.SOPLAR AIRE 1/4 PIC/  
 LARG.CROWN  
 REF B=3.74 REF C=3.93



**SAG-0907** REF A 3.06  
 PZA | PISTOLA DE AIRE JUEGO 7 PCS  
 WOLFGAN  
 REF B=4.65 REF C=4.9



**SAG-0920** REF A 31.99  
 PZA | PIST.P/ASFALT.Y ARENAR(SAND  
 BLASTING  
 REF B=48.68 REF C=51.24



**45cm**



**SEG-0300** REF A 6.88  
 PZA | CONO SEGURI.GOMA C/TIRA REFLEX  
 45cm  
 REF B=10.47 REF C=11.02



**SEG-6517** REF A 2.94  
 CJA | MASCARILL.CUBRE BOCA AZUL LIGA  
 C/50  
 REF B=4.47 REF C=4.71



**SOL-5260** REF A 53.74  
 PZA | REGULADOR ACET.T/HARRIS MEDIO  
 WT  
 REF B=81.8 REF C=86.1

2.1/2"  
0-30PSI

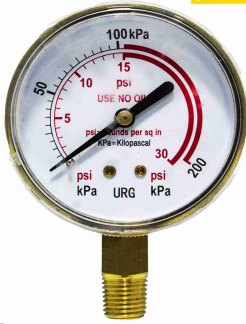

weldtech®

SOL-6000 REF A 5.22  
PZA |MAN.2.1/2 ACET/PROP\*BAJ 0-30PSI  
WT  
REF B=7.94 REF C=8.36

2.1/2"  
0-400PSI

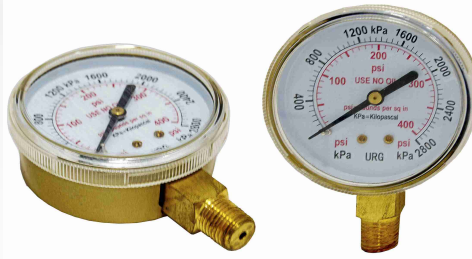

weldtech®

SOL-6030 REF A 5.22  
PZA |MAN.2.1/2 ACET/PROP-ALT 0-400PSI  
W  
REF B=7.94 REF C=8.36

#10

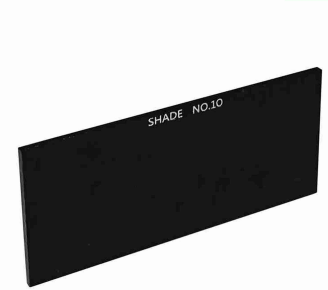

SOL-9807 REF A 0.17  
PZA |VIDRIO P/SOLDAR OSCURO #10  
ALEMAN  
REF B=0.25 REF C=0.27

#12



SOL-9818 REF A 0.15  
PZA |VIDRIO P/SOLDAR OSCURO #12  
ALEMAN  
REF B=0.23 REF C=0.24

#4



weldtech®

SOL-9823 REF A 0.84  
PAR |VIDRIO P/LENTE D/SOLDAR #4 WT  
1PAR  
REF B=1.28 REF C=1.34

#5



weldtech®

SOL-9824 REF A 0.84  
PAR |VIDRIO P/LENTE D/SOLDAR #5 WT  
1PAR  
REF B=1.28 REF C=1.34

#6

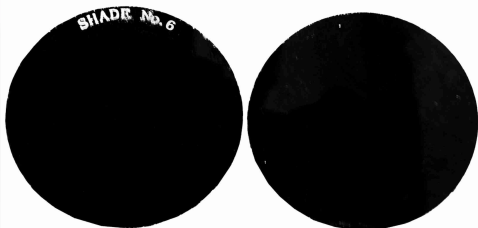

weldtech®

SOL-9825 REF A 0.84  
PAR |VIDRIO P/LENTE D/SOLDAR #6 WT  
1PAR  
REF B=1.28 REF C=1.34

40%ESTAÑO  
60%PLOMO  
0.8mm



TOP SECURITY®  
Tools for Professionals

SOL-9920 REF A 0.84  
PZA |SOLDADURA ESTAÑO TUBITO 60/40  
0.8M  
REF B=1.27 REF C=1.34

40%ESTAÑO  
60%PLOMO  
1.00mm



SOLDER  
CORE WIRE

SOL-9924 REF A 3.18  
RL |SOLDADURA C/RES.40/60 1.0MM  
100G CF  
REF B=4.83 REF C=5.09

13mts x 1.0mm  
80grs



**SOL-9925** REF A 0.8  
RLL | SOLDAD.C/RESIN.1.0m 13MTS.80GR  
DIES  
REF B=1.22 REF C=1.28

1.00mm  
x225gr



**SOL-9927** REF A 5.49  
RLL | SOLDAD.C/RESIN.1.0m 225GRS  
35mts DT  
REF B=8.36 REF C=8.8

HASTA  
250amp



**SOL-9950** REF A 22.64  
PZA | SWICHE UNI.P/MAQ.SOLDAR HASTA  
250A  
REF B=34.46 REF C=36.27

400ML  
LIMON



**SPR-0979** REF A 2.44  
PZA | SPR.SILICON LIMON MULT.USO 400ML  
Q7  
REF B=3.71 REF C=3.91

378ml  
OLOR FRESA



**SPR-0980** REF A 2.24  
PZA | SPRAY SILICONA FRESA 400ML UDEKE  
REF B=3.41 REF C=3.58

378ml  
OLOR LIMON



**SPR-0983** REF A 2.24  
PZA | SPRAY SILICONA LIMON 400ML UDEKE  
REF B=3.41 REF C=3.58

378ml  
OLOR UVA



**SPR-0986** REF A 2.24  
PZA | SPRAY SILICONA UVA 400ML UDEKE  
REF B=3.41 REF C=3.58

450ML



**SPR-0990** REF A 2.51  
PZA | SPRAY FORMULA MECANICA 450ML  
ZASC  
REF B=3.81 REF C=4.01

500ML



**SPR-1001** REF A 3.77  
PZA | SPR.SELLADOR ANTIGOTEO NEG 500M  
ZAS  
REF B=5.74 REF C=6.05





650ml



**Q7**

SPR-1002 REF A 2.17  
PZA |S.LIMPIAD/MULT.TAPICER.ESPUM.650  
Q7  
REF B=3.3 REF C=3.48



650ml

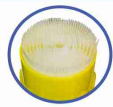

**DIESEL TOOLS**

SPR-1004 REF A 2.4  
PZA |S.ESPUMA LIMPIAD-  
MULTIPROPOS.650.DI  
REF B=3.66 REF C=3.85



650ML

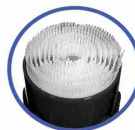

**ZASC**

SPR-1005 REF A 2.2  
PZA |S.ESPUMA LIMPIADOR-  
MULTIUSO.650M ZASC  
REF B=3.36 REF C=3.53



500ml

**ZASC**

SPR-1007 REF A 2.66  
PZA |SPR.LIMPIAD.MOTOR EN ESPUMA  
650M ZA  
REF B=4.04 REF C=4.25



450ml

**Q7**

SPR-1015 REF A 2.56  
PZA |SPRAY.LIMPIADOR CONTACTO 450ML  
Q7  
REF B=3.89 REF C=4.09



650ml

**Q7**

SPR-1017 REF A 2.17  
PZA |SPR.LIMPIADOR/ABRILL.CAUCHO  
650M Q7  
REF B=3.3 REF C=3.48



650ml

**ZASC**

SPR-1018 REF A 3.11  
PZA |SPR.LIMPIAD.ESPUMA.CAUCHO 650M  
ZASC  
REF B=4.73 REF C=4.98



650ml

**DIESEL TOOLS**

SPR-1019 REF A 3.01  
PZA |SPR.LIMPIAD.ABRILL.CAUCHO 650M  
DIES  
REF B=4.58 REF C=4.82

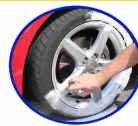

450ml

**DIESEL TOOLS**

SPR-1025 REF A 2.37  
PZA |SPRAY LIMPIAD.CARBURADOR 450M  
DIESE  
REF B=3.61 REF C=3.8



100ml



SPR-1030 REF A 1.64  
PZA | SPR.ACEITE PENETRANTE 100ML  
DIES300  
REF B=2.49 REF C=2.62



210ml



SPR-1031 REF A 1.87  
PZA | SPR.ACEITE PENETRANTE 210ML  
DIES300  
REF B=2.85 REF C=3



450ml



SPR-1032 REF A 2.35  
PZA | SPR.ACEITE PENETRANTE 450ML 303  
UDE  
REF B=3.58 REF C=3.77



450ml



SPR-1040 REF A 2.37  
PZA | SPRAY GRASA LIQUIDA  
TRANSP.400ML Q7  
REF B=3.61 REF C=3.8



450ml



SPR-1041 REF A 4.41  
PZA | SPR.GRASA BLANCA LITIO P/METAL  
450M  
REF B=6.71 REF C=7.06



450ml



SPR-1043 REF A 2.61  
PZA | SPR.LIMPIAD.GRAS/  
RESIDU.ACEITE.450M  
REF B=3.97 REF C=4.17



450ml



SPR-1049 REF A 2.4  
PZA | SPR.DENEGRAS.INOX.CERAM.VIDRIO  
450  
REF B=3.66 REF C=3.85



TOT-1700 REF A 4.8  
SET | EXTRACTOR D/TORNILLO SET 6PCS  
T061  
REF B=7.31 REF C=7.7



2175 Psi  
7.5M



TOT-4600 REF A 14.83  
PZA | MANGUERA HIDROJET 2175PSI 7.5MT  
751  
REF B=22.57 REF C=23.76



**30Pcs**

**TOTAL TOOLS**

**TOT-5800 REF A 5.49**  
 SET | PUNTAS DESTORNILLADOR SET 30PC T306

REF B=8.36 REF C=8.8



**5TON x3MTS**

**DIESEL TOOLS**

**VIT-6630 REF A 138.94**  
 PZA | SEÑORITA CADENA 5 TON. DIESEL 21/5T

REF B=211.47 REF C=222.58



**1TONx3M**

**CROWNMAN PROFESSIONAL**

**VIT-6640 REF A 94.39**  
 PZA | SEÑORITA 1 TON. 3mt CADENA CROWNAMN

REF B=143.66 REF C=151.21



**2TONx3M**

**CROWNMAN PROFESSIONAL**

**VIT-6643 REF A 121.91**  
 PZA | SEÑORITA 2 TON. 3mt CADENA CROWNAMN

REF B=185.55 REF C=195.3



**3TONx3M**

**CROWNMAN PROFESSIONAL**

**VIT-6646 REF A 167.13**  
 PZA | SEÑORITA 3 TON. 3mt CADENA CROWNAMN

REF B=254.38 REF C=267.75



**1 TON x3M**

**ZASC**

**VIT-6652 REF A 53.71**  
 PZA | SEÑORITA 1 TON. CON 3MTS CADENA ZAS

REF B=81.74 REF C=86.04



**2 TON x5M**

**ZASC**

**VIT-6661 REF A 91.18**  
 PZA | SEÑORITA 2 TON. CON 5MTS CADENA ZASC

REF B=138.78 REF C=146.07



**2TON**

**VITAL**

**VIT-6995 REF A 157.55**  
 PZA | SEÑORITA D/CADENA VITAL 2 TON

REF B=239.8 REF C=252.4